

Class 150 • Outside Screw & Yoke • Bolted Bonnet

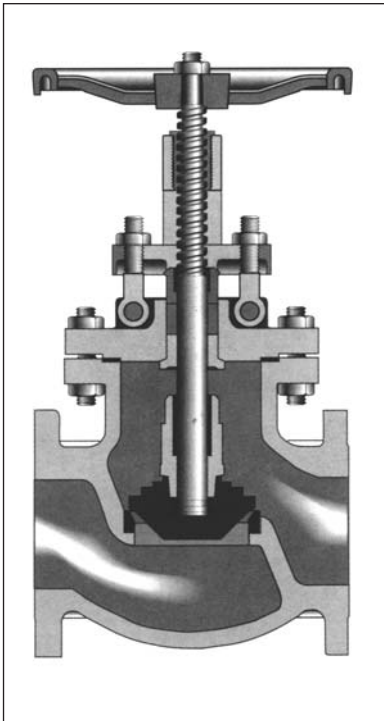

Figure 143XU
Flanged

Size Range:
2 - 12 inches

Pressure Temperature Rating
Carbon Steel
ASTM A216 Grade WCB
285 psi @ -20°F to 100°F

Materials of Construction

Description	Material
Body	A216 WCB
Bonnet	A216 WCB
Seat Rings	Hardfaced
Disc	13% CR Overlay
Stem	410 SS
Packing	Graphite
Bonnet Gasket	Soft Iron
Back Seat	410 SS
Disc Stem Nut	410 SS
Disc Washer	Carbon Steel
Gland	410 SS
Gland Flange	WCB
Eye Bolt	Steel
Eye Bolt Nuts	A563 Gr. A or 0
Pins	-
Bonnet Studs	A193 Gr. B7
Bonnet Nuts	A194 Gr. 2H
Handwheel	WCB
Handwheel Nut	A194 Gr. 2H
I.D. Tags	SS
I.D. Pins	Steel

Industry Standards

Steel Valves	ANSI B16.34
Face-to-Face/End-to-End	ANSI B16.10
Flange Dimensions	ANSI B16.5
Testing	API 598
Acceptance	API RP591

Dimensions and Weights

Valve Size	Weight (pounds)	Dimensions (inches)		
		A	B Valve Open	C
2	53	8.00	14.00	8.00
2½	70	8.50	15.00	8.00
3	90	9.50	17.00	10.00
4	143	11.50	20.00	12.00
6	246	16.50	24.00	16.00
8	392	19.50	25.00	16.00
10	605	24.50	29.00	20.00
12	900	27.50	38.00	20.00

