

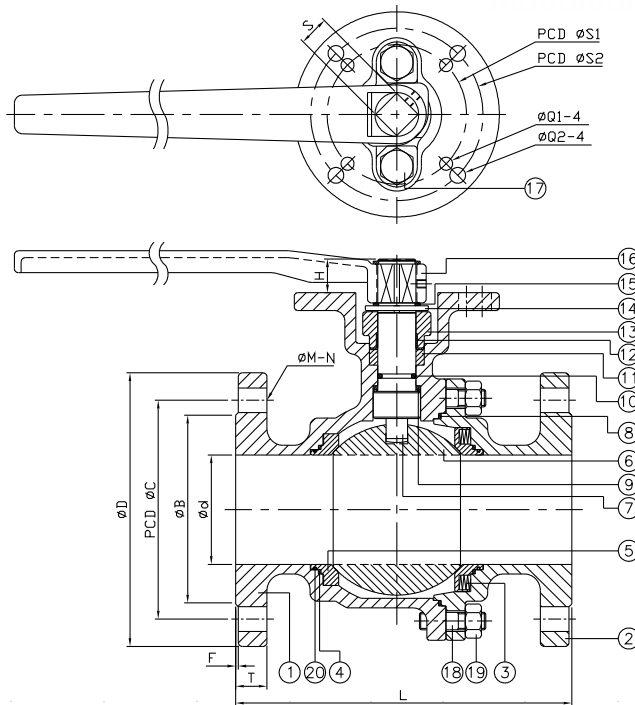

★ METAL SEAT



FEATURES

- Full port, 1-1/2"~6" (DN40~DN150)
- W.P. : PN10/16/25/40
CLASS 150/300/600
- W.T. : -20°C~500°C (-4°F~1022°F)
- Investment casting
- Blow-out proof stem
- Anti-static device
- ISO 5211 Direct mounting pad
- **Metal seat**
- Flange dimension:
ANSI B16.10 CLASS 150/300/600
DIN 2501
- Face to face:
ANSI B16.5 CLASS 150/300/600
DIN 3202

ITEM	PARTS	MATERIAL
1	BODY	ASTM A351-CF8M
2	CAP	
3	SPRING	AISI 316
4	SEAT SEAL	GRAPHITE
5	METAL SEAT	AISI 316 + Solder Stellite #6
6	BALL	AISI 316 + Hard Chrome Plated
7	STEM	AISI 316
8	BODY SEAL	GRAPHITE + AISI 316
9	THRUST WASHER	GRAPHITE + PTFE
10	O-RING	VITON
11	PACKING	GRAPHITE + PTFE
12	GLAND WASHER	PTFE
13	GLAND	AISI 304
14	STOP PLATE	
15	SNAP RING	
16	HANDLE	FCD45
17	BOLT	AISI 304
18	NUT	ASTM A194-8
19	STUD	ASTM A193-B8
20	O-RING	VITON

CLASS 150

DN	d	B	C	D	F	H	L	S	S1	S2	T	Q1	Q2	M	N
40	38.1	73.15	98.55	127	1.52	16	165.1	13.97	50.04	70.1	14.22	8.13	9.91	15.75	4
50	50.04	91.95	120.65	152.4	1.52	16	178.05	13.97	50.04	70.1	15.75	8.13	9.91	19.05	4
65	62.99	104.65	139.7	177.8	1.52	19.05	189.99	17.02	70.1	102.11	17.53	9.91	11.94	19.05	4
80	80.01	127	152.4	190.5	1.52	24.13	202.95	22.1	102.11	124.97	19.05	11.94	13.97	19.05	4
100	98.04	157.23	190.5	228.6	1.52	24.13	229.11	22.1	102.11	124.97	23.88	11.94	13.97	19.05	8
125	124.97	185.67	215.9	254	1.52	29.97	356.11	26.92	124.97	139.95	23.88	13.97	16	22.35	8
150	151.89	215.90	241.3	279.4	1.52	29.97	393.95	26.92	124.97	139.95	25.4	13.97	16	22.35	8

unit:mm

NPS	d	B	C	D	F	H	L	S	S1	S2	T	Q1	Q2	M	N
1-1/2"	1.5	2.88	3.88	5	0.06	0.63	6.5	0.55	1.97	2.76	0.56	0.32	0.39	0.62	4
2"	1.97	3.62	4.75	6	0.06	0.63	7.01	0.55	1.97	2.76	0.62	0.32	0.39	0.75	4
2-1/2"	2.48	4.12	5.5	7	0.06	0.75	7.48	0.67	2.76	4.02	0.69	0.39	0.47	0.75	4
3"	3.15	5	6	7.5	0.06	0.95	7.99	0.87	4.02	4.92	0.75	0.47	0.55	0.75	4
4"	3.86	6.19	7.5	9	0.06	0.95	9.02	0.87	4.02	4.92	0.94	0.47	0.55	0.75	8
5"	4.92	7.31	8.5	10	0.06	1.18	14.02	1.06	4.92	5.51	0.94	0.55	0.63	0.88	8
6"	5.98	8.5	9.5	11	0.06	1.18	15.51	1.06	4.92	5.51	1	0.55	0.63	0.88	8

unit:in



8F., No.201, Sec. 2, Tiding Blvd., Neihu District, Taipei City 114, Taiwan R.O.C.

TEL: +886-2-26585800

FAX: +886-2-26582266 / 27997766