

# Model 1216F

## TECHNICAL DATA SHEET



### Description

Type	Safety and Relief valve
Connections	Threaded BSP / NPT
Rating	PN-40
Material	Stainless steel 316 L
Temperature range	-10 to +350°C
Cryogenic service until	-196°C

### Requirements

Calculation	EN-4126-1 / 7
Design	EN-12516-1, EN-4126-1 / 7 DIN 259 and ANSI B2.1
Materials	EN
Inspection	EN-4126-1 / 7

### Construction and materials

Item	Description	Material	
		Standard	Cryogenic
1	Nozzle	SA 351 CF-3M	SA 351 CF-3M
2	Body	SA 351 CF-3M	SA 351 CF-3M
4	Cap	SA 351 CF 8	SA 351 CF 8
5	Disc	316 L SS	316 L SS
6	Guide	SA 351 CF-3M	SA 351 CF-3M
7	Push Road	316 L SS	316 L SS
8	Spring Button	303 SS	303 SS
9	Ajusting Screw	303 SS	303 SS
10	Tensor Nut	303 SS	303 SS
11	Spring	303 SS	17 / 7PH
12	Lever	SA 351 CF 8	SA 351 CF 8
17	Release nut	306 L SS	306 L SS
18	Lever axis	303 SS	303 SS
19	Packing lever axis	303 SS	303 SS
20	Gasket	PTFE	PCTFE
21	Gasket	PTFE	PCTFE
22	Gasket	Viton	PCTFE
28	Soft seat	Viton / PTFE	Metal

○ Recommended spare parts

Palanca manual  
Lifting device

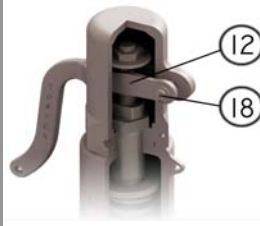

Palanca estanca  
Sealed packing lever



T. Prueba  
Test gag

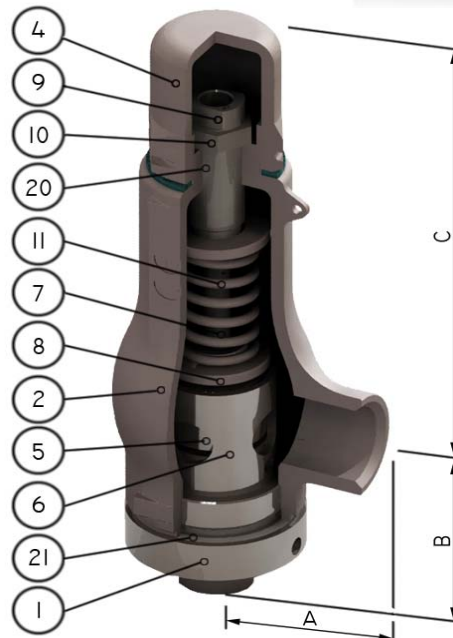

Obturator o-ring  
Disc o-ring

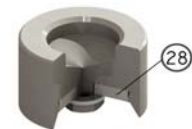

### Technical information

Applications	Steam, gases, vapours and liquids
Min. Set pressure	0,2 barg
Overpressure	10%
Blowdown	Gases 10%, liquids 20%
Tolerance Set pressure	± 3%
Discharge coefficients	k= 0,55 for gases k= 0,48 for liquids

### Dimensions

Inlet	Outlet	Orifice	Area (mm <sup>2</sup> )	A (mm)	B (mm)	C (mm)	Weight (kg)
1/2"	3/4"	13	133	45	57	155	2,2
1/2"	1"	13	133	45	57	155	2,2
3/4"	1"	14	154	45	57	155	2,2
1"	1"	16	201	45	60	155	2,2
1"	1 1/4"	16	201	45	61	155	2,3
1"	2"	22	380	62	87	234	4,5
1 1/4"	1 1/4"	18	254	45	62	155	2,4
1 1/2"	2"	28	616	62	89	234	4,6
2"	2"	32	804	62	93	234	5,1



