

To AS 2638.2
Stem sealing exchangeable under pressure
Face to face dimension to AS 2638.2
Flange and drilling to AS 4087 Figure B5 (AS 2129 Table D)

Use:

For water, sewage and neutral liquid applications

Valve designed for use up to 70°C

Where applicable; for AS 4020 compliance, max temp = 40°C

Note: Always observe pipe material recommended operating temperatures

Tests:

Hydraulic test to AS 2638.2:

Seat: 16 bar

Body: 24 bar

Operating torque test

Optional extras:

- Handwheel
- Flange gasket kits
- ISO flanging for actuation
- Gearbox
- User specified flange drilling

Materials:

- Gland flange, body and bonnet Ductile iron, 500-7 to AS 1831
- Stem cap Ductile iron, 400-12 to AS 1831
- Coating Fusion bonded epoxy resin - Internally and externally to AS 4158
- Stem Stainless steel 431
- Stem sealing NBR wiper ring, 3 NBR O-rings
- Wedge Ductile iron, 500-7 to AS 1831, core fully vulcanised with EPDM rubber, with integral wedge nut of dezincification resistant brass, CZ 132 to AS 2345
- Bushing Polyamid
- Thrust collar and stem seal box Dezincification resistant brass, CZ 132 to AS 2345
- Bonnet bolts DN50 - DN250 Stainless steel 304, sealed with hot melt
DN300 - DN400 Grade 12.9, sealed with hot melt
- Gland flange bolts Stainless steel 316
- Bonnet gasket EPDM rubber



Australian Standard
 AS2638.2-2006
 Lic. SMK02420
 SAI Global



AVK Australia's website contains the latest product information and data sheets.

Designs, materials and specifications shown are subject to change without notice due to our continuing program of product development.



AVK Australia Pty Ltd
 559A Grand Junction Road, Wingfield, SA 5013 Australia
 Tel: +61 8 8368 0900
 Fax: +61 8 8368 0970
 E-mail: info@avkvalves.com.au
 www.avkvalves.com.au
 Copyright© AVK Group A/S 2008

3N5740IQ
 August 2008

To AS 2638.2
 Stem sealing exchangeable under pressure
 Face to face dimension to AS 2638.2
 Flange and drilling to AS 4087 Figure B5 (AS 2129 Table D)

Component list

- | | | | |
|------------------|------------------|----------------------|-------------------|
| 1. Valve body | 7. Bonnet gasket | 13. Gland flange | 19. Stem cap |
| 2. Wedge casting | 8. Bonnet | 14. Bushing | 20. Stem cap bolt |
| 3. Wedge rubber | 9. Hot melt seal | 15. Washer | 21. Insert |
| 4. Stem nut | 10. O-ring seal | 16. O-ring seals (2) | |
| 5. Stem | 11. Stem collar | 17. Gland bolts | |
| 6. Bonnet bolts | 12. O-ring seal | 18. Wiper ring | |

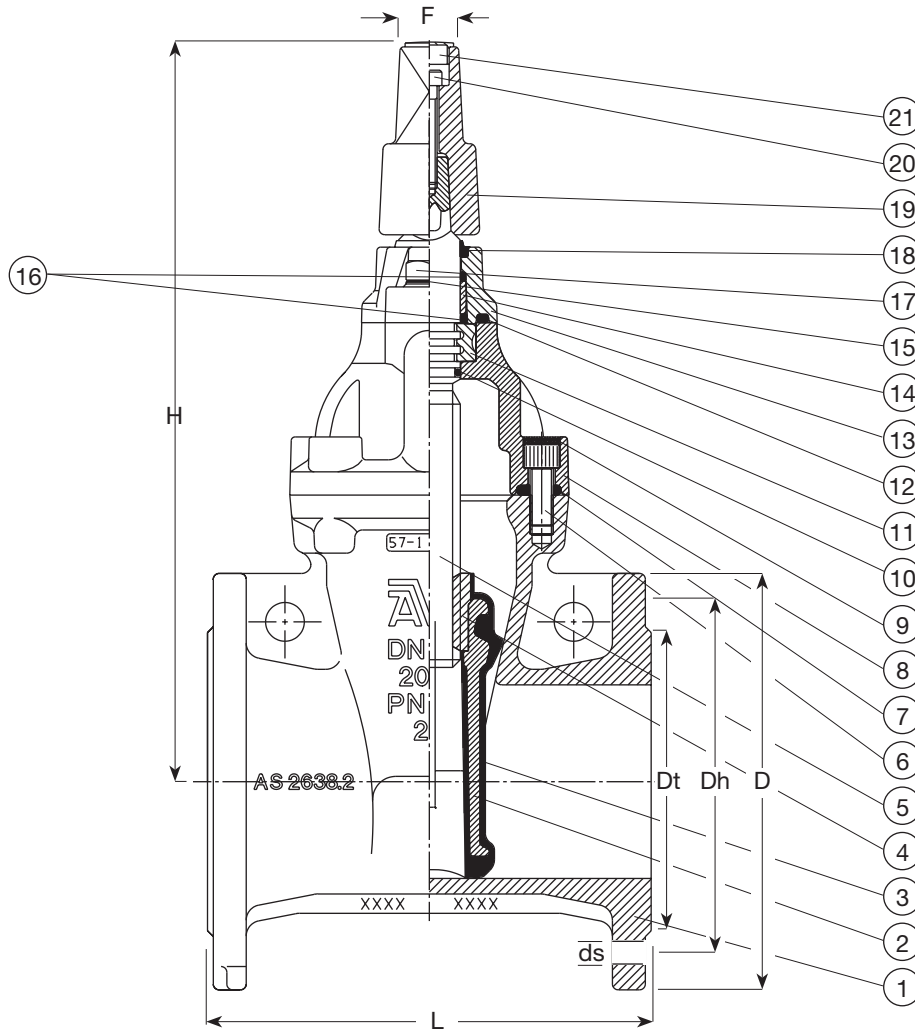

Ref. nos. CC	Ref. nos. ACC	DN	L mm	H mm	Dt mm	D mm	Dh mm	ds mm	Holes	F mm	Weight kilos
57-050-402	57-050-403	50 *	178	335	98	165	114	18.5	4	35	17
57-065-402	57-065-403	65 *	190	344	103	185	127	18.5	4	35	18
57-080-402	57-080-403	80	203	350	122	185	146	18.5	4	35	19
57-100-402	57-100-403	100	229	380	154	215	178	18.5	4	35	27
57-150-402	57-150-403	150	267	485	209	280	235	18.5	8	35	49
57-200-402	57-200-403	200	292	595	264	335	292	18.5	8	35	74
57-225-402	57-225-403	225	305	595	296	370	324	18.5	8	35	98
57-250-402	57-250-403	250	330	680	328	405	356	22.5	8	35	102
57-300-402	57-300-403	300	356	755	376	455	406	22.5	12	35	147
57-375-402	57-375-403	375	381	905	463	550	495	26.5	12	35	240
57-400-402	57-400-403	400	406	930	503	620	521	26.5	12	35	285

*Not specified in AS 2638.2

