

DIAVAL® DIAPHRAGM VALVES

Design Advantages and Cost Saving Benefits

Diaphragm Valves proved to be the answer to many process engineers' greatest desire of reliability at an acceptable cost of ownership. Of simple and reliable design, diaphragm valves offer secure operation with full leaktight at the plant. The maintenance, when required, is limited to the replacement of the diaphragm, the bolted bonnet design permits to dismantle the valve without removing the valve body from the pipe work.

The body seatless design eases the internal lining, which opens a broad range to inexpensive options to process engineers when selecting materials resistant to corrosion and abrasion duties. Conventional isolating valves would demand expensive exotic materials to resist the effects of severe corrosion whereas a duly lined iron based material can do the job.

DIAVAL portfolio clearly meets the requirements of modern industrial processes and the needs of all engineers. Through constant product development and own polymer research technology, DIAVAL Diaphragm Valves are a reliable alternative to existing costly and expensive to maintain conventional valves.

DIAVAL INTERNATIONAL manufacture one of the largest Diaphragm Valves portfolio comprehensive of body linings, diaphragm grades and actuation currently available in the international market. Your DIAVAL Team is available to guide you along a great cost saving experience.



DIAVAL range of superior design and major cost saving benefits, for secure and full leaktight operation under the most severe circumstances.

The DIAVAL range is totally interchangeable with other diaphragm valves in the market thus easing the plant choice.

Valve stroke Indicator; a yellow position indicator gives clear and positive valve position from any angle.

Greased for life valve spindle; spindle chamber incorporates a grease reservoir that lubricates the spindle along operations thus avoiding valve spindle jamming. Sealed bonnet arrangements available for toxic and hazardous fluids.

Valve stroke stopper; the bonnet design prevents over closure of the valve thus avoiding early diaphragm rupture.

Ergonomically Design Hand wheel; great comfort and ease of operation. Other operation options such as actuators, padlocks, interlocking, extended spindle and others are available from DIAVAL.

Self draining; weir valves are self draining when installed at an angle of 20° above horizontal. ST and Full Flow valves are self cleaning with an unobstructed bore.

Diaphragms; wide range of diaphragm materials to meet the needs of today's industrial processes and standards. Resilient diaphragms provides 100% leak-tight shut off and isolates all bonnet parts from the line fluid.

Safety; Optional Sealed bonnet arrangements available for toxic and hazardous fluids, Interlocking arrangement, padlocking and flange sealing coating.

Linings; porous free chemically resistant linings designed to eliminate the need of expensive metals. Wide range of polymers and fluoropolymers available to match all industrial needs. Full face rubber lining removes the need for gaskets unlike spigot face lining.

Body end connections; flanged and screwed ends to meet all European, Imperial and American standards. Other end styles available for the aseptic range.

DIAVAL® DIAPHRAGM VALVES
 Design Attributes of Weir Valves

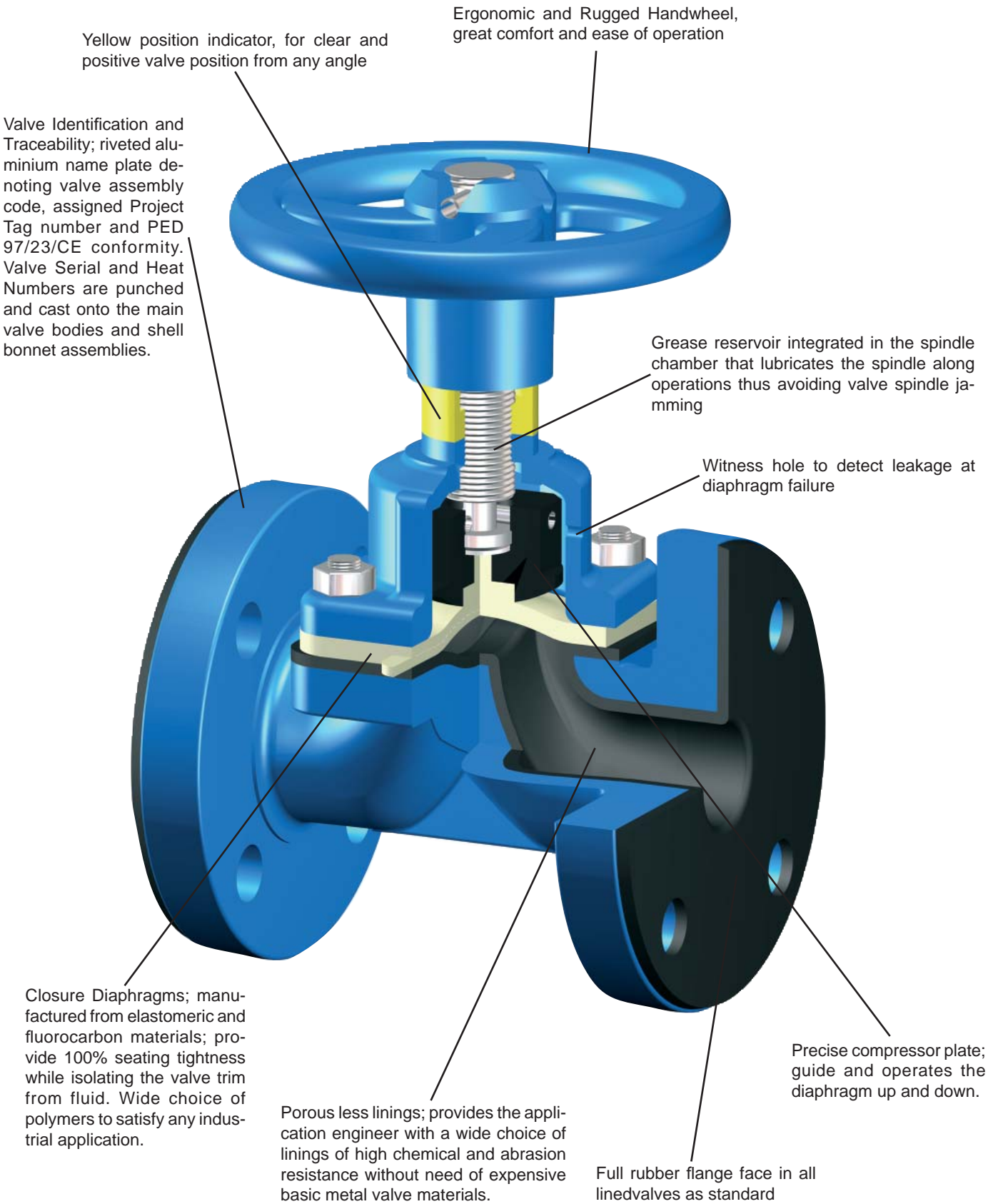

DIAVAL® WEIR TYPE DIAPHRAGM VALVES

Rubber lined valves with flanged ends

Standard Materials

Part	Description	Material
01	Body	Ductile or Cast Iron
1A	Body lining	Rubber lined
02	Diaphragm	Rubber
03	Bonnet*	Ductile or Cast Iron
04	Compressor	Cast Iron
05	Compressor pin	Steel
06	Spindle	Steel
07	Handwheel	Cast Iron
08	Handwheel pin	Steel
09	Body studs **	Steel
10	Body nuts **	Steel
11	Thrust washer	Nylon

* With eye bolts in DN 200-300 to ease handling

** DN15-80: 4 Nos / DN100-125: 8 Nos / DN150: 10 Nos / DN200-300: 14Nos

Body Material Options

Cast Iron (Grey)	
EN1561	GJL-250 (GG-25)
ASTM	A 126 Class B
Ductile Iron (SG Iron)	
EN1563	GJS-400-15 (GGG-40) ^a
EN1563	GJS-450-10 (GGG-40.3) ^b
ASTM	A536 Grade 65-45-12
Carbon Steel	
EN10213	GP240GH+N (1.0619+N)
ASTM	A 216 WCB
Stainless Steel 316	
EN10088-1	X5CrNiMo17-12-2 (1.4401)
ASTM	A 351 CF8M
Stainless Steel 316L	
EN10088-1	X2CrNiMo17-12-2 (1.4404)
ASTM	A 351 CF3M
Bronze	
EN1982	CuSn5Zn5Pb5-C (CC491K)
EN1982	CuSn7Zn2Pb3-C (CC492K)
ASTM	B62
Iron Alloys	
Chromium Iron 24%, 30%, etc.	

a) Standard for unlined and rubber lined valves

b) Standard for fluoropolymer lined valves

Other Material Options

- Body studs and nuts in St. Steel A2 or A4
- Further material options available on request
- Materials given to be understood as minimum standard provided under name designation

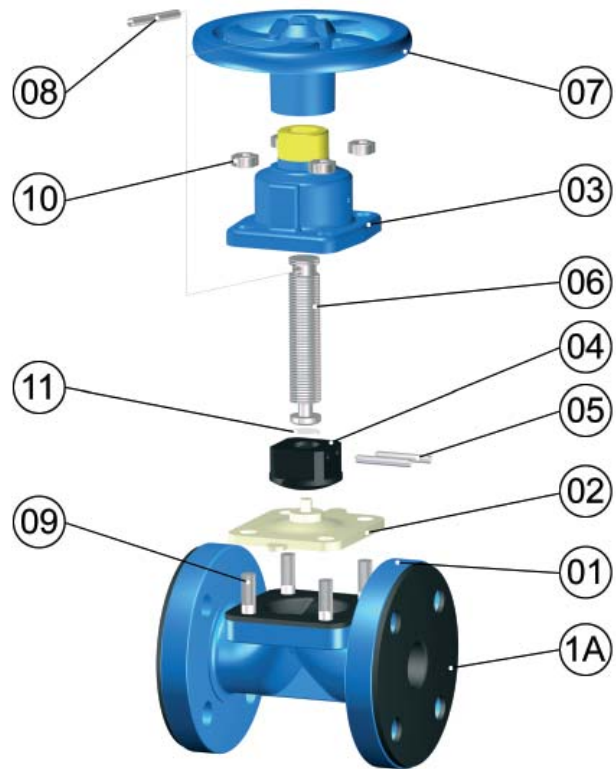

Body Rubber Lining Material Options

Material	Identification
Hard Rubber - Ebonite (HR)	Sky Blue Spot
Butyl Rubber (BR)	Dark Blue Spot
Soft Rubber (SR)	White Spot
Neoprene® Rubber	Red Spot
Hypalon® Rubber	Green Spot
White Natural	
Linatex®	

Diaphragm Options

Material	Code
Natural Rubber	D10
White Natural Rubber	D15
EPDM Rubber	D20
Butyl Rubber	D30
Nitrile Rubber	D40
Neoprene® Rubber	D50
Hypalon® Rubber	D60
Viton® Rubber	D70
Linatex®	
PTFE/EPDM	D93/20
PTFE/Butyl Rubber	D93/30
PTFE/Viton®	D93/70

Special vacuum reinforced diaphragms add code letter [V] e.g. D10V