

## DIAVAL® DIAPHRAGM VALVES

### Design Advantages and Cost Saving Benefits

Diaphragm Valves proved to be the answer to many process engineers' greatest desire of reliability at an acceptable cost of ownership. Of simple and reliable design, diaphragm valves offer secure operation with full leaktight at the plant. The maintenance, when required, is limited to the replacement of the diaphragm, the bolted bonnet design permits to dismantle the valve without removing the valve body from the pipe work.

The body seatless design eases the internal lining, which opens a broad range to inexpensive options to process engineers when selecting materials resistant to corrosion and abrasion duties. Conventional isolating valves would demand expensive exotic materials to resist the effects of severe corrosion whereas a duly lined iron based material can do the job.

**DIAVAL** portfolio clearly meets the requirements of modern industrial processes and the needs of all engineers. Through constant product development and own polymer research technology, DIAVAL Diaphragm Valves are a reliable alternative to existing costly and expensive to maintain conventional valves.

**DIAVAL INTERNATIONAL** manufacture one of the largest Diaphragm Valves portfolio comprehensive of body linings, diaphragm grades and actuation currently available in the international market. Your DIAVAL Team is available to guide you along a great cost saving experience.



DIAVAL range of superior design and major cost saving benefits, for secure and full leaktight operation under the most severe circumstances.

The DIAVAL range is totally interchangeable with other diaphragm valves in the market thus easing the plant choice.

# **Valve stroke Indicator;** a yellow position indicator gives clear and positive valve position from any angle.

# **Greased for life valve spindle;** spindle chamber incorporates a grease reservoir that lubricates the spindle along operations thus avoiding valve spindle jamming. Sealed bonnet arrangements available for toxic and hazardous fluids.

# **Valve stroke stopper;** the bonnet design prevents over closure of the valve thus avoiding early diaphragm rupture.

# **Ergonomically Design Hand wheel;** great comfort and ease of operation. Other operation options such as actuators, padlocks, interlocking, extended spindle and others are available from DIAVAL.

# **Self draining;** weir valves are self draining when installed at an angle of 20° above horizontal. ST and Full Flow valves are self cleaning with an unobstructed bore.

# **Diaphragms;** wide range of diaphragm materials to meet the needs of today's industrial processes and standards. Resilient diaphragms provides 100% leak-tight shut off and isolates all bonnet parts from the line fluid.

# **Safety;** Optional Sealed bonnet arrangements available for toxic and hazardous fluids, Interlocking arrangement, padlocking and flange sealing coating.

# **Linings;** porous free chemically resistant linings designed to eliminate the need of expensive metals. Wide range of polymers and fluoropolymers available to match all industrial needs. Full face rubber lining removes the need for gaskets unlike spigot face lining.

# **Body end connections;** flanged and screwed ends to meet all European, Imperial and American standards. Other end styles available for the aseptic range.

## DIAVAL® WEIR TYPE DIAPHRAGM VALVES

### Unlined Screwed valves

#### Main Dimensions

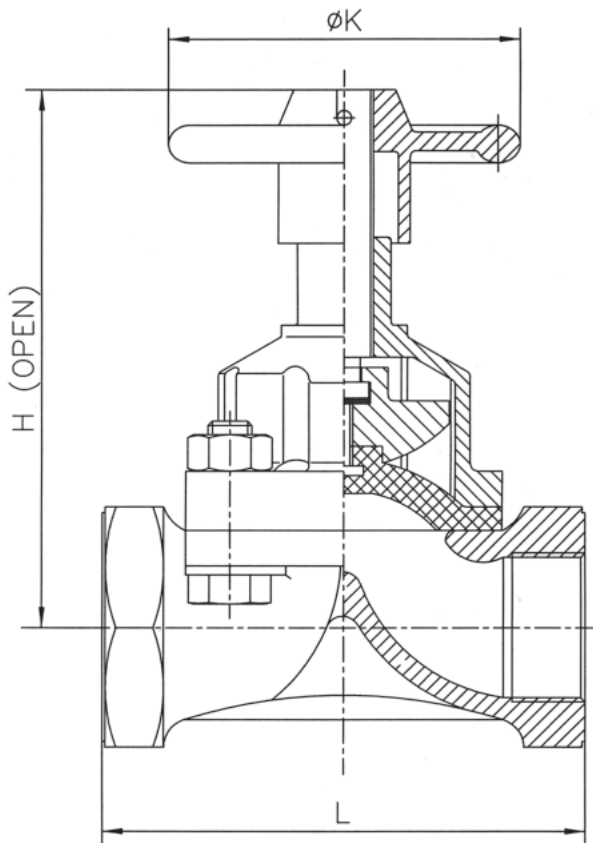

SIZE	DN	L (1)	L (2)	H(1) (open)	H(2) (open)	ØK (1)	ØK (2)	Weight
3/8"	10	50	---	70	---	45	---	1.2
1/2"	15	66	108	95	106	75	100	1.5
3/4"	20	85	117	105	117	75	100	2.0
1"	25	110	127	122	141	85	120	3.2
1 1/4"	32	124	146	148	152	120	120	4.0
1 1/2"	40	140	159	155	176	120	120	6.0
2"	50	165	190	183	196	120	164	8.0
2 1/2"	65	203	---	212	---	165	---	10.5
3"	80	254	---	256	---	230	---	17.5

\* Approx. Weight in kg, based on Cast Iron body material.

\* Dimensions in mm, only orientative. Arrangement drawings for approval on request.

(1): Standard dimensions for cast and ductile iron valves

(2): Standard dimensions for stainless steel valves

#### Manufacture Design Standards:

- Harmonised Standard EN13397 (November 2001), equivalent to MSS-SP-88-1993 (Reaffirmed 2001)
- QA certified to ISO 9001:2000
- According to Pressure Equipment Directive PED 97/23/EC Article 3 - Paragraph 3
- Testing standards EN12266-1 (March 2003) and BS6755 part 1 (1986)
- Marking according to EN 19 (April 2002)
- Face to face dimensions according to Diaval® standard
- Screwed ends to BSP (BS 21 parallel or taper), NPT (ANSI B1.20.1), other options on request

#### Operating parameters:

Valve bodies design pressure range: PN16 (DN10-50) PN10 (DN65-80)

See Data Sheet n° OP for complete overview of operating parameters

## DIAVAL® WEIR TYPE DIAPHRAGM VALVES

### Unlined Screwed valves

#### Standard Materials

Part	Description	Material
01	Body	Ductile or Cast Iron
02	Diaphragm	Rubber
03	Bonnet	Ductile or Cast Iron
04	Compressor	Cast Iron
05	Compressor pin	Steel
06	Spindle	Steel
07	Handwheel	Cast Iron
08	Handwheel pin	Steel
09	Body studs (4 Nos)	Steel
10	Body nuts (4 Nos)	Steel
11	Thrust washer	Nylon

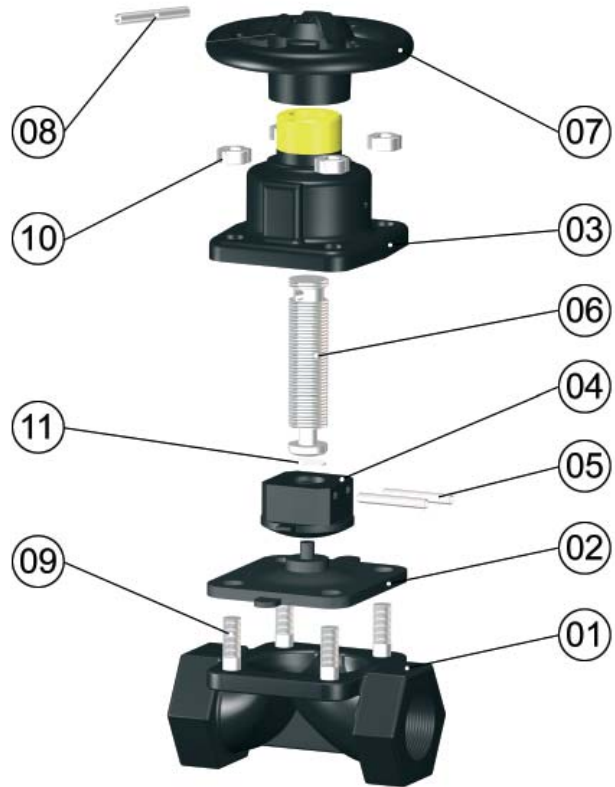

#### Body Material Options

##### Cast Iron (Grey)

EN1561	GJL-250 (GG-25)
ASTM	A 126 Class B

##### Ductile Iron (SG Iron)

EN1563	GJS-400-15 (GGG-40)
EN1563	GJS-450-10 (GGG-40.3)
ASTM	A536 Grade 65-45-12

##### Carbon Steel

EN10213	GP240GH+N (1.0619+N)
ASTM	A 216 WCB

##### Stainless Steel 316

EN10088-1	X5CrNiMo17-12-2 (1.4401)
ASTM	A 351 CF8M

##### Stainless Steel 316L

EN10088-1	X2CrNiMo17-12-2 (1.4404)
ASTM	A 351 CF3M

##### Bronze

EN1982	CuSn5Zn5Pb5-C (CC491K)
EN1982	CuSn7Zn2Pb3-C (CC492K)
ASTM	B62

##### Iron Alloys

Chromium Iron 24%, 30%, etc.

#### Diaphragm Options

Material	Code
Natural Rubber	D10
White Natural Rubber	D15
EPDM Rubber	D20
Butyl Rubber	D30
Nitrile Rubber	D40
Neoprene® Rubber	D50
Hypalon® Rubber	D60
Viton® Rubber	D70
Linatex®	
PTFE/EPDM	D93/20
PTFE/Butyl Rubber	D93/30
PTFE/Viton®	D93/70

Special vacuum reinforced diaphragms add code letter [V] e.g. D10V

#### Other Material Options

- Body studs and nuts in St. Steel A2 or A4
- Further material options available on request
- Materials given to be understood as minimum standard provided under name designation