



JR Series

Gas Pressure Reducing Valves

GAS PRESSURE REDUCING VALVES

The LowFlow JR Series line of high pressure regulators have the ability to handle very high pressures and very low flows. These valves are typically used in research and sampling systems for general, corrosive and specialty gas service, and for non-cavitating liquids. Typical applications include gas chromatography and flame ionization detectors, as well as other industrial controls.



Features:

- Top entry design facilitates in-line cleaning and maintenance
- Barstock construction guarantees material integrity and surface finish
- High flow rate coupled with high rangeability reduces need for reduced trim sizes
- Optimized internal volume
- Proprietary Jorlon diaphragm material provides exceptionally long life
- Soft seat material for ANSI Class VI shutoff



A Division of
Jordan Valve
3170 Wasson Road
Cincinnati, OH 45209

toll free. 800.543.7311
local. 513.533.5600
fax. 513.871.0105

www.lowflowvalve.com

JR SERIES SPECIFICATIONS

Line Size: 1/4", 3/8", 1/2" (DN8, DN10, DN15)

End Connections

- SWE
- NPT

Soft Seat Materials for ANSI Class VI Shut-off

- PTFE to +150°F (+66°C)
- PEEK to +350°F (+177°C)

Body Material

- 316L SST – Standard
- Contact factory for other body/trim/seat materials

Diaphragm Material: Jorlon

Maximum Inlet Pressure: 4000 psig (276 bar)

Pressure at Maximum Temperature: 2165 psi @ 350°F (149 bar @ 177°C) with PEEK seat; 3600 psi @ 150°F (248 bar @ 66°C) with PTFE seat

Maximum Pressure Drop: 3000 psi (207 bar)

Spring Ranges

- 5 – 50 psi (0,3 – 3,4 bar)
- 25 – 100 psi (1,7 – 6,9 bar)
- 50 – 150 psi (3,4 – 10,3 bar)
- 25 – 250 psi (1,7 – 17 bar)
- 100 – 475 psi (7 – 33 bar)
- 200 – 750 psi (14 – 52 bar)

Flow Characteristics

- Cv 0.012
- Cv 0.08
- Cv 0.20

Options

- Panel Mounting
- Captured Vent
- Self Relieving

OPTIONS & DEFINITIONS

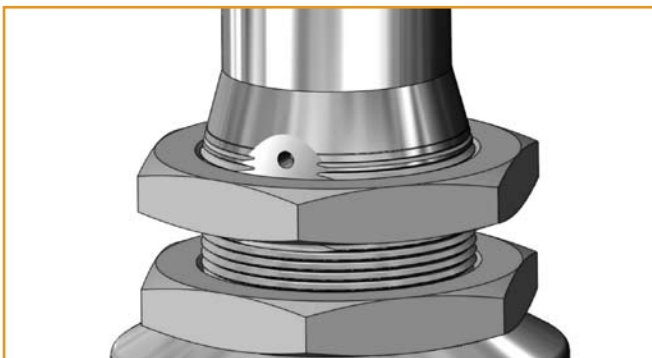

Panel Mount Option

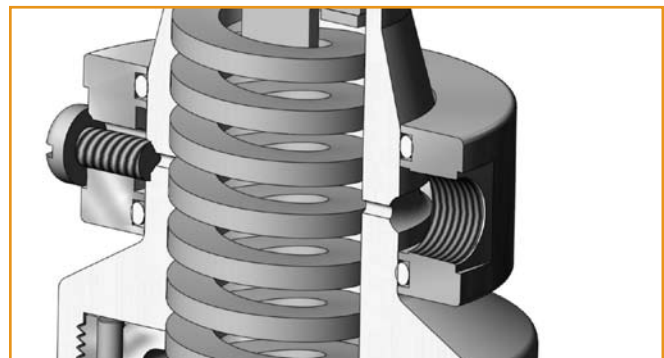

Captured Vent Option (1/8" NPT)

Captured Vent The captured vent design is for maximum safety for the user when handling toxic or hazardous media. It features a 1/8" FNPT port located on the spring housing. The user can easily tube this vent to a safe location. This option can be incorporated into a self-relieving regulator that provides an additional port to permit the safe expulsion of hazardous media.

Panel Mount The panel mount feature requires a panel cut out of 1-1/2", complete with a threaded spring housing, and a panel mount ring to secure the regulator.

Self Relieving The self relieving option is used for internal venting of downstream pressure. From a practical standpoint, it allows for immediate reduction in pressure setpoints and automatically alleviates regulator lock up.

JR SERIES FEATURES & BENEFITS

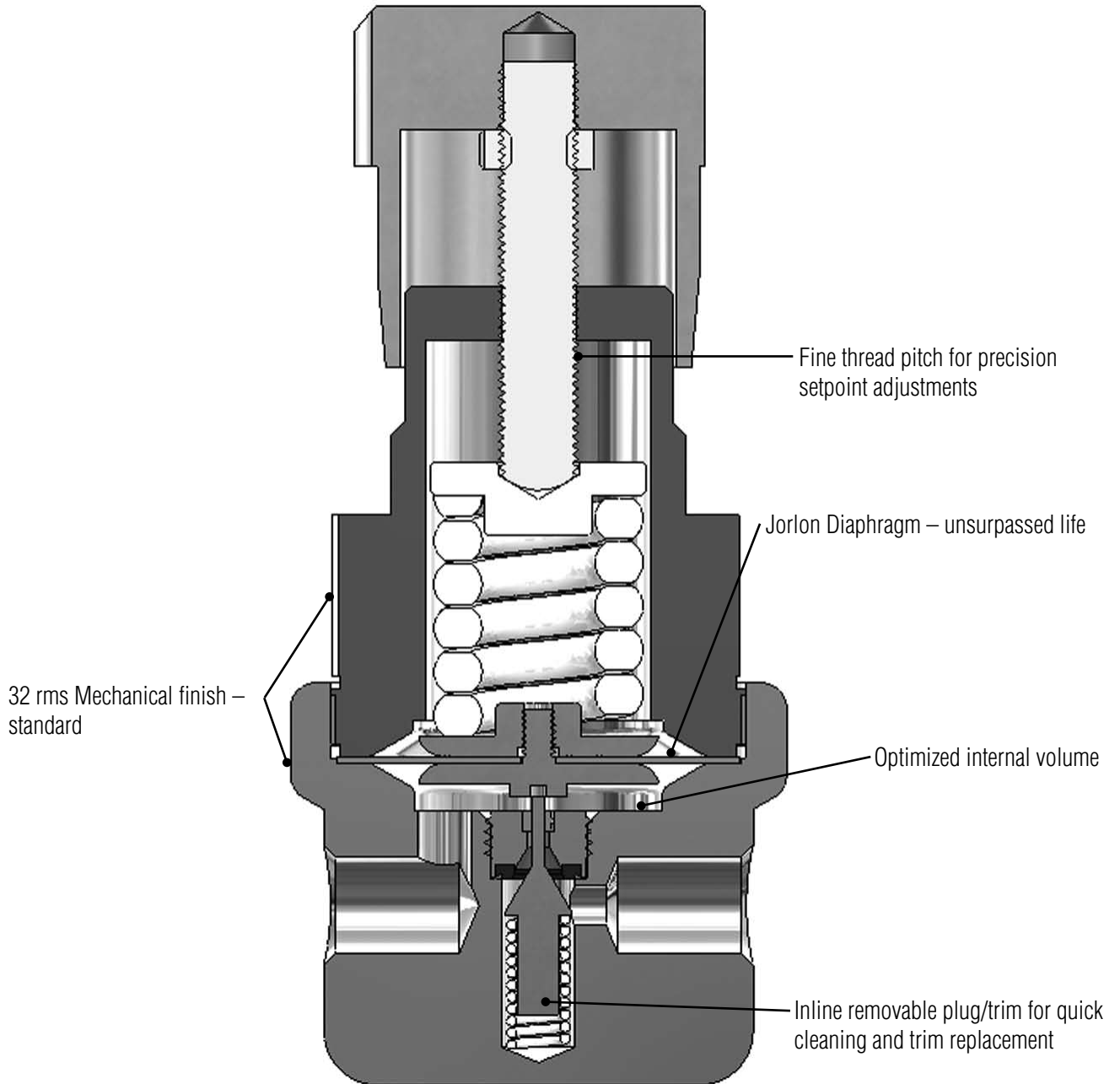

JR SERIES TRIM FLOW GRAPHS

- 0.012Cv – 5 - 50 PSI RANGE

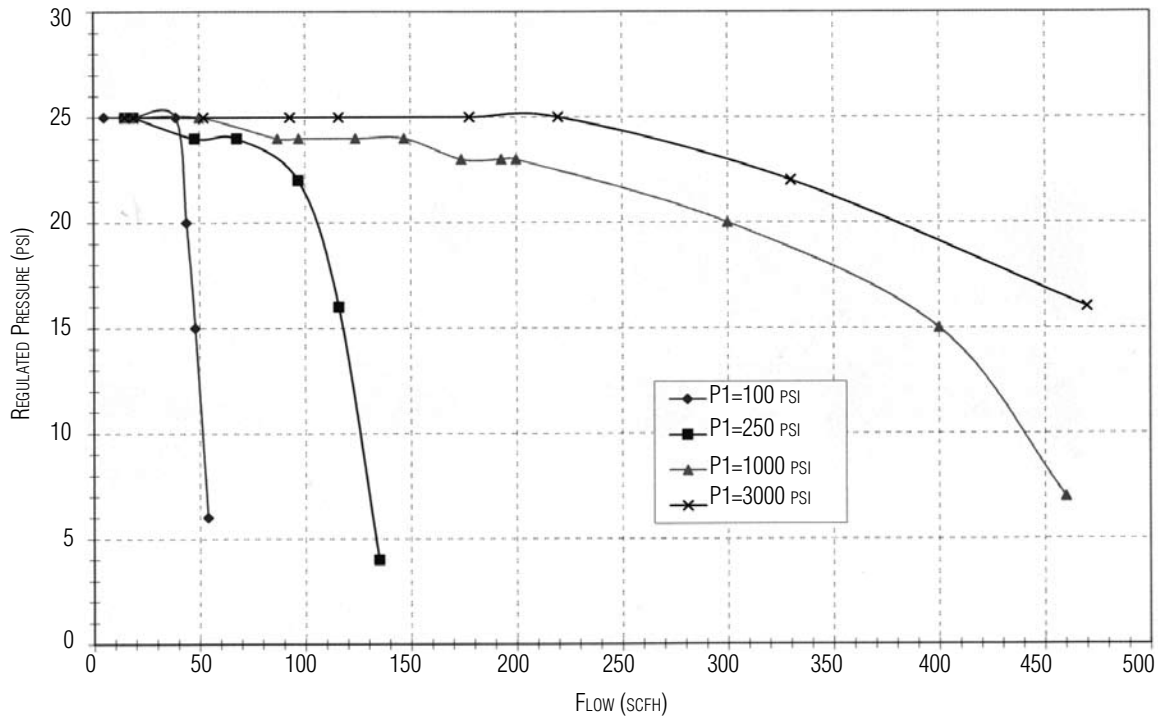

- 0.012Cv – 50 - 150 PSI RANGE

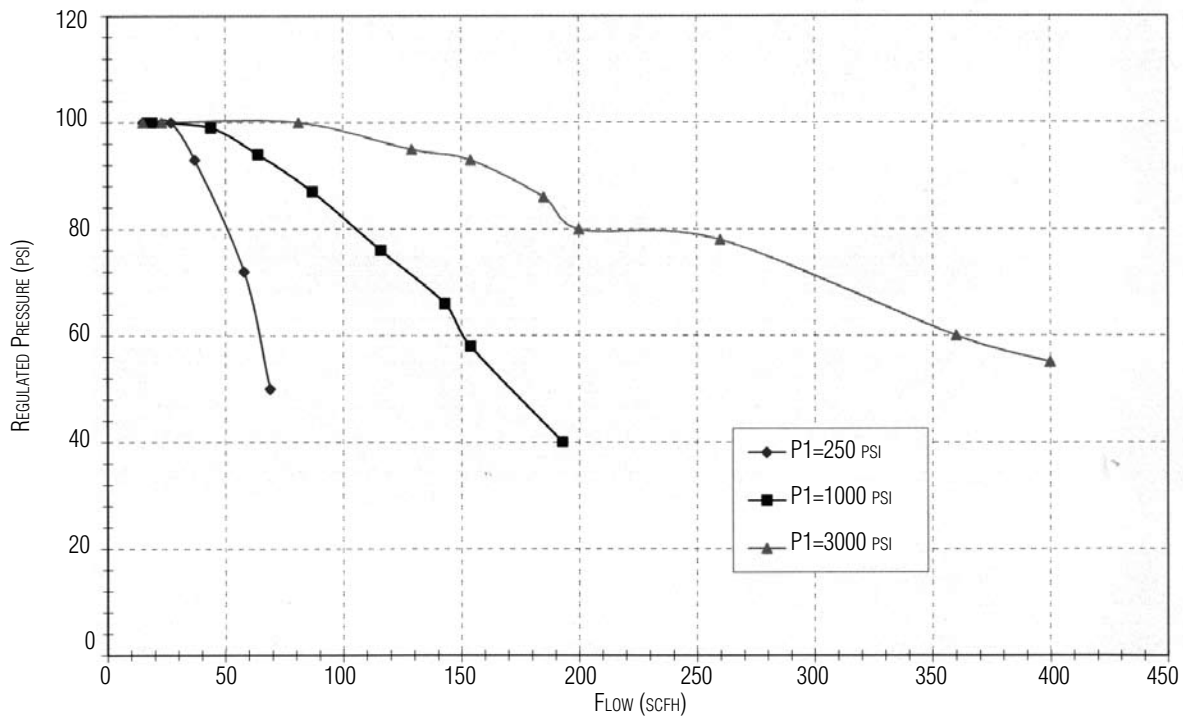

JR SERIES TRIM FLOW GRAPHS

- 0.08Cv – 5 - 50 PSI RANGE

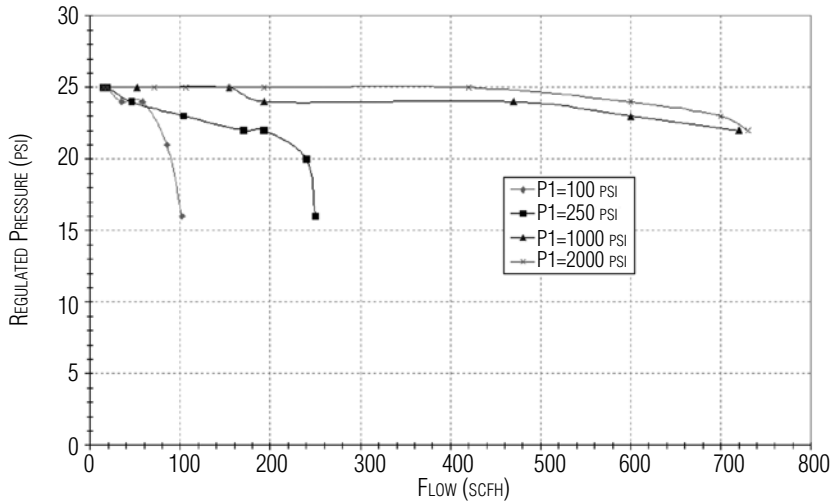

- 0.08Cv – 50 - 150 PSI RANGE

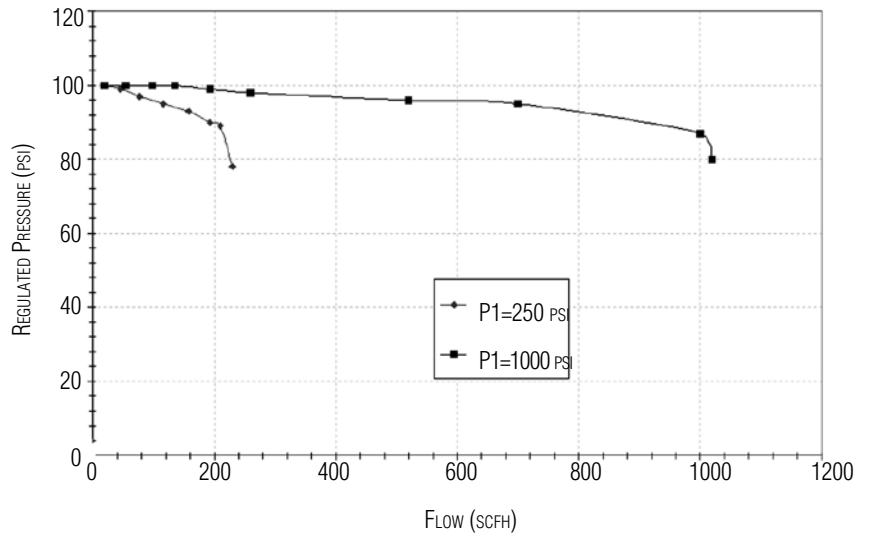

- 0.08Cv – 100 - 475 PSI RANGE

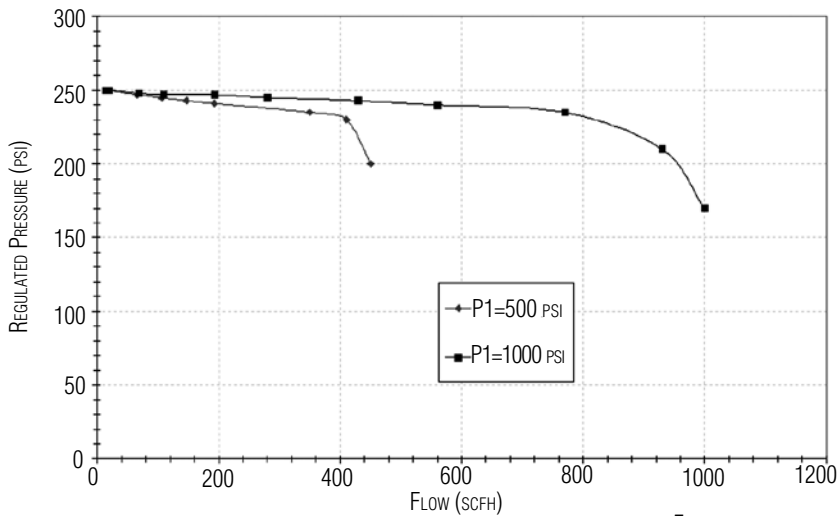

JR SERIES TRIM FLOW GRAPHS

- JR = 0.2 Cv – 5 - 50 PSI RANGE

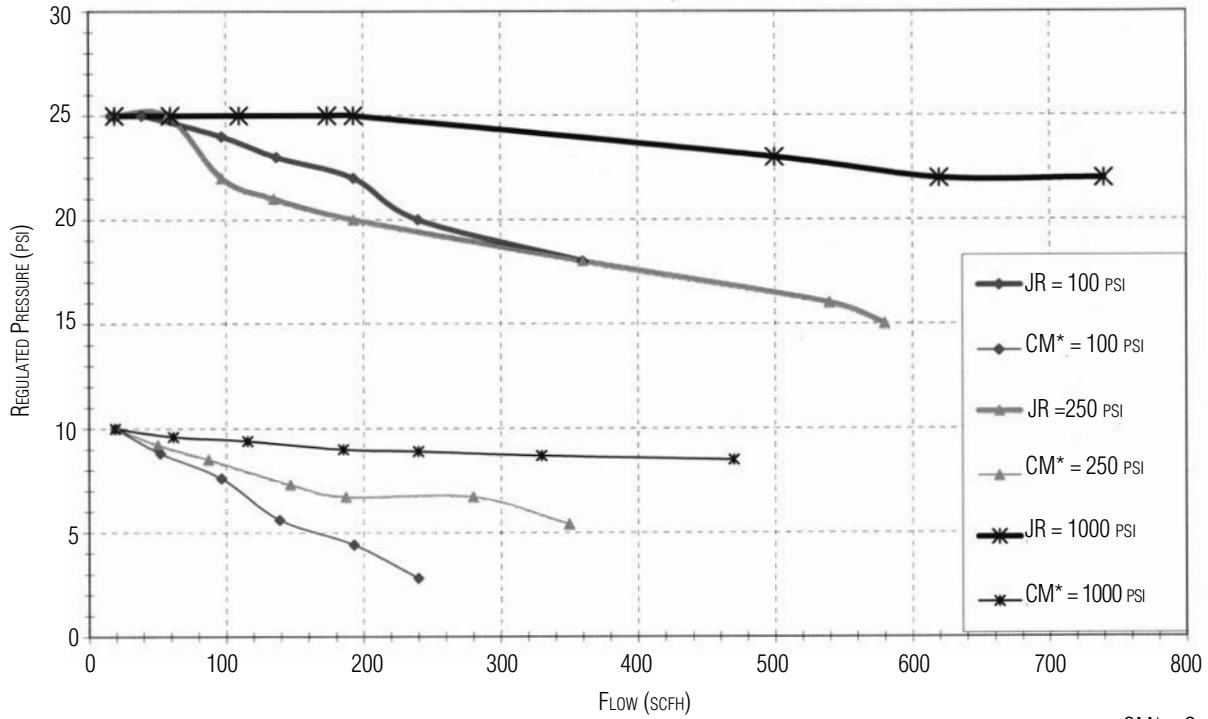

CM* = COMPETITIVE MODEL

- JR = 0.2 Cv – 50 - 150 PSI RANGE

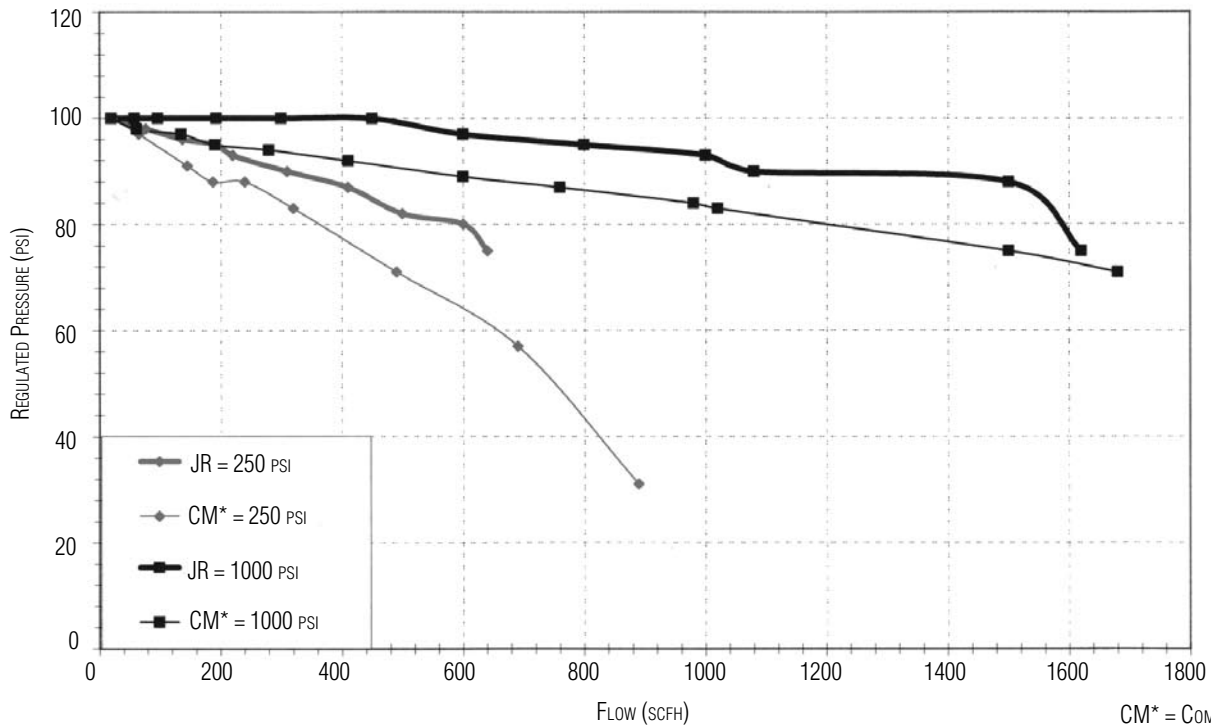

CM* = COMPETITIVE MODEL

JR SERIES TRIM FLOW GRAPHS

- 0.2 Cv – 100 - 475 PSI RANGE

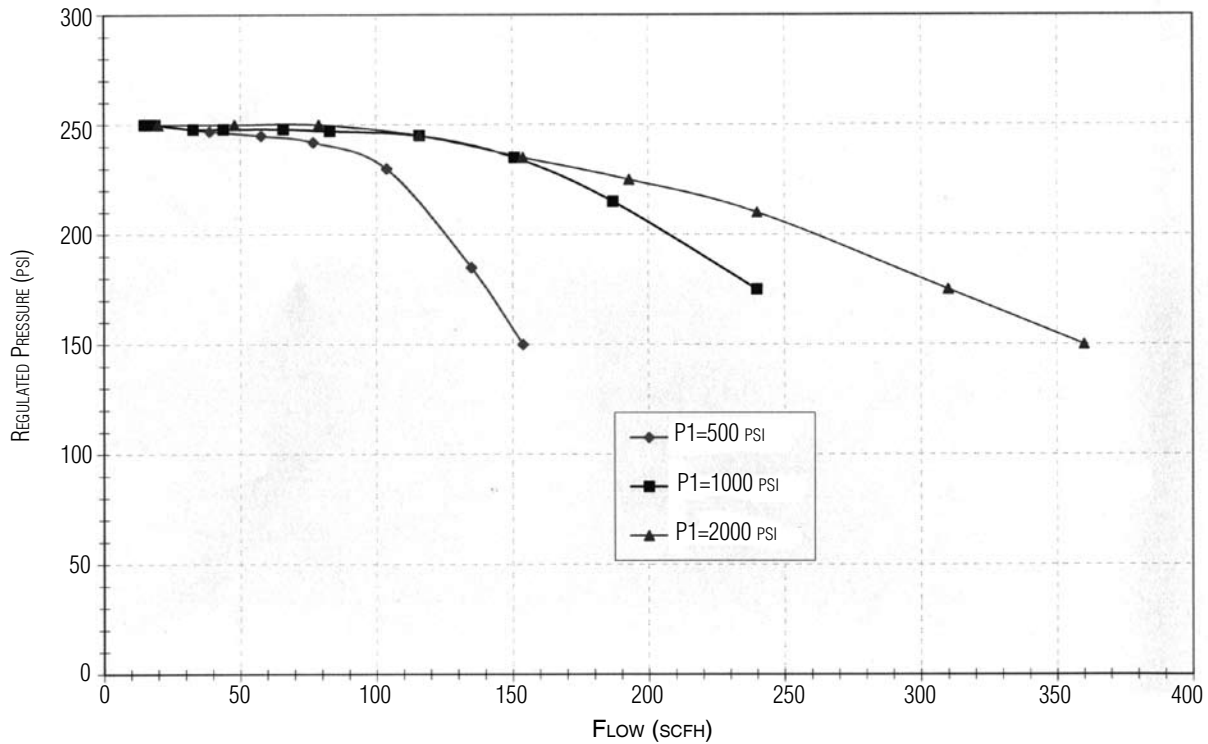

JR SERIES FLOW DIMENSIONS

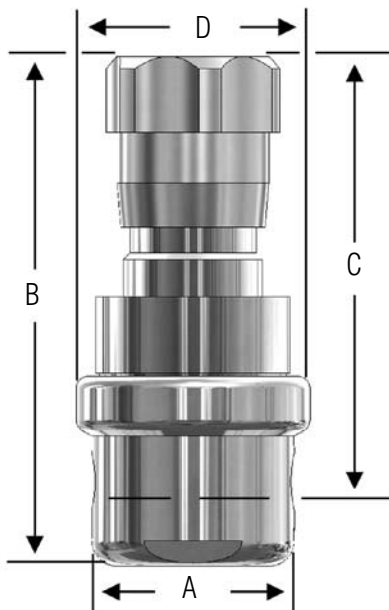

- **JR Series, Inches**

VALVE SIZE	DIMENSIONS, INCHES				WEIGHT, LBS
	A	B	C	D	
1/4"	2.00	5.03	4.20	2.31	3.4
3/8"	2.00	5.03	4.20	2.31	3.4
1/2"	2.75	5.03	4.20	2.31	4.2

- **JR Series, Metric**

VALVE SIZE	DIMENSIONS, MM				WEIGHT, KGS
	A	B	C	D	
DN8	50,8	128	107	58,7	1,5
DN10	50,8	128	107	58,7	1,5
DN15	69,9	128	107	58,7	1,9

JR SERIES FLOW CONFIGURATIONS

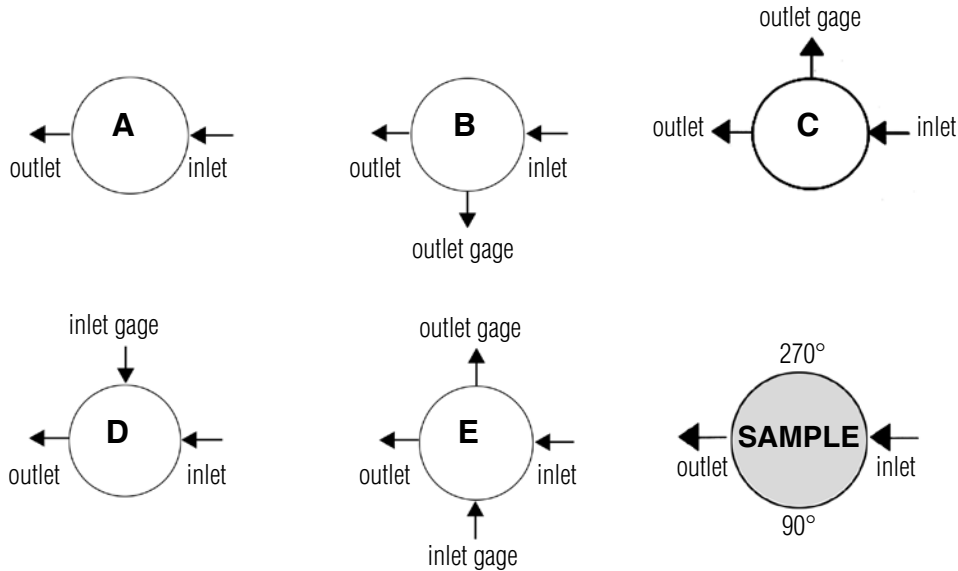

* Gage ports are 1/4" FNPT (consult factory for required alternative)
Consult factory for other porting options

JR SERIES ORDERING SCHEMATIC

Model	Material	1 & 2	3 & 4	5 & 6	7 & 8	9 & 10	11 & 12	13 & 14	15	16	17
	—	/									

Model	
JR	Pressure Reducing Valve

Material	
6L	Stainless Steel 316L

1 & 2		Body Feature	
End Connection		Port Configuration	
A	FNPT 1/4"	A	Port "A"
B	FNPT 3/8"	B	Port "B"
C	FNPT 1/2"	C	Port "C"
		D	Port "D"
		E	Port "E"
ZZ	Non-Standard		

3 & 4		Trim	
1S		Cv 0.012	
2S		Cv 0.08	
3S		Cv 0.2	
1R		Cv 0.012 Self-Relieving	
2R		Cv 0.08 Self-Relieving	
3R		Cv 0.2 Self-Relieving	
ZZ		Non-Standard	

5 & 6		Seat Material	
T1		PTFE Cv 0.012	
T2		PTFE Cv 0.08	
T3		PTFE Cv 0.2	
P1		PEEK Cv 0.012	
P2		PEEK Cv 0.08	
P3		PEEK Cv 0.2	

ORDERING SCHEMATIC



JR SERIES ORDERING SCHEMATIC (CON'T)

Model	Material	1 & 2	3 & 4	5 & 6	7 & 8	9 & 10	11 & 12	13 & 14	15	16	17
—	/										

7 & 8	Range Spring/Outlet Pressure
E1	5- 50 psi
E2	25 - 100 psi
E3	50 - 150 psi
E4	75 - 250 psi
E5	100 - 475 psi
E6	200 - 750 psi

9 & 10	Diaphragm Material
JL	Jorlon
ZZ	Non-Standard

11 & 12	Actuator
	Ranges E1 thru E5
SK	Standard
CV	Captured Vent
PM	Panel Mount
ZZ	Non-Standard
	Range E6
6K	Standard
6V	Captured Vent
6M	Panel Mount
ZZ	Non-Standard

13 & 14	Inlet Gauge
AA	0 - 30 psig
BB	0 - 60 psig/bar (dual)
CC	0 - 100 psig/bar (dual)
DD	0 - 160 psig/bar (dual)
EE	0 - 200 psig/bar (dual)
FF	0 - 300 psig/bar (dual)
GG	0 - 400 psig/bar (dual)
HH	0 - 600 psig/bar (dual)
JJ	0 - 1000 psi/bar (dual)
KK	0 - 2000 psi/bar (dual)
LL	0 - 3000 psi/bar (dual)
MM	0 - 4000 psi/bar (dual)
NN	None
ZZ	Non-Standard

15	Outlet Gauge
A	0 - 30 psig
B	0 - 60 psig/bar (dual)
C	0 - 100 psig/bar (dual)
D	0 - 160 psig/bar (dual)
E	0 - 200 psig/bar (dual)
F	0 - 300 psig/bar (dual)
G	0 - 400 psig/bar (dual)
H	0 - 600 psig/bar (dual)
J	0 - 1000 psi/bar (dual)
N	None
ZZ	Non-Standard

16	SEP Compliance
0	None
G	SEP Compliant
Z	Non-Standard

17	Accessories
0	None
S	Clean for Oil Free
X	Clean for Oxygen
Z	Non-Standard