

DIMENSIONES DEL CONJUNTO ACTUADOR + REDUCTOR

DIMENSIONS ACTUATOR + GEARBOX

ACTUADOR ACTUATOR	REDUCTOR GEARBOX	INSTALACION INSTALLATION	DIMENSIONES (mm)					SET DIMENSIONS(mm)						
			A	B	C	D	E	F	G	S	H	X		
			S,E/S,R	D,E/D,A										
PA00-PA00S	RD-415	IRD-41500	152		52	267	111	116	188	118	129	140	129	
PA05-PA05S			201		62	168	128						135	
PA10-PA10S			224		63	172	132						138	
PA15-PA15S			264		71	188	148						146	
PA20-PA20S	RD-420	IRD-42020	310		75	313	156	122	242	142	171	200	151	
PA25-PA25S		IRD-42025	356		89	219	184						164	
P30-P30S	RD-330	IRD-33030	479	349	94	375	211	145	350	194	253	300	167	
P40-P40S	RD-440	IRD-44040	598	444	120	465	272	163	380	205	278	500	221	
P50-P50S	RD-345	IRD-34550	694	524	135	487	313	160	393	223	282	400	240	
	RD-350	IRD-35050				503	313	175	460	250	335	600	238	
PA70-PA70S	RD-360	IRD-36070	743		216	630	428	194	516	280	376	700	304	
	RD-370	IRD-37070				635	428	209	581	345	409	800	313	

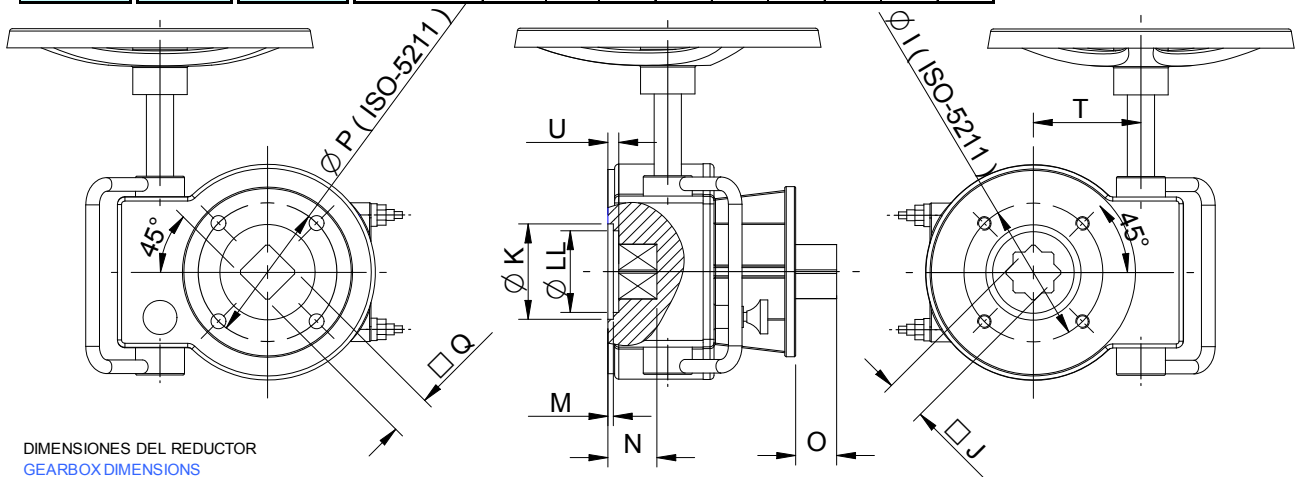

DIMENSIONES DEL REDUCTOR  
GEARBOX DIMENSIONS

REDUCTOR GEARBOX	LADO VALVULA ISO-5211					VALVE SIDE					LADO ACTUADOR ACTUATOR SIDE					PESOS WEIGHTS	PAR (Nm) Torque (Nm)
	STANDARD	OPTION	□ Q	STAND.	OPTION	U	K	LL	M	N min.	O max.	ISO-5211 STANDARD	OPTION	□ Q	T		
RD-415	F05-F07	-	17	-	6,5	35	30	1	35	19	F05-F07	-	17	40,5	4,4 Kg	125	
RD-420	F07	-	17	-	5	55	38	4	35	19	F07	-	17	52	7,4 Kg	270	
RD-330	F07-F10-F12	-	27	17	-	60	-	6	30	29	F07-F10-F12	-	27	64,5	17 Kg	750	
RD-440	F12	-	36	-	6	95	85	1	30	38	F12	-	36	86	22,6 Kg	1150	
RD-345	F14	F10-F12	27	-	-	75	-	4	65	38	F14	F10-F12	36	84	21 Kg	1450	
RD-350	F14	F10-F12-F16	36	27	-	88	-	3	60	38	F14	F12-F16	36	107,5	34 Kg	2485	
RD-360	F16	F12-F14	46	27-36	-	102	-	7	65	48	F16	F12-F14	46	127	54 Kg	3390	
RD-370	F16-F25	-	46	55	-	130	-	6	70	48	F16-F25	-	46	155	80 Kg	7450	

DIMENSIONES EN (mm)  
DIMENSIONS IN (mm)