

Mark 50 Series

Self-Operated Back Pressure Regulators

The Mark 50 Sliding Gate Back Pressure Regulator is used to regulate upstream pressure at a predetermined setpoint. The spring in the Mark 50 holds the sliding gate seats in their normally closed position.

The upstream pressure is sensed beneath the diaphragm. As the upstream pressure exceeds the setpoint, pressure is exerted on the diaphragm which raises the stem to modulate the disc (the movable component of the sliding gate seat set) toward the open position. As the seats open, upstream pressure will be regulated to the required setpoint. A decrease in pressure relaxes the spring and diaphragm to move the seats toward the closed position.



MARK 50 FEATURES

This brochure includes the following Series:

- **MK50:** a line of self-operating back pressure regulators designed with Jordan Valve's sliding gate seats.
- **MK51:** The MK51 features a larger diaphragm than a standard MK50 to provide even greater sensitivity and more accurate regulation of your required setpoint.
- **MK50QC:** The MK50QC features a "Quick Change" dome for simple range spring replacements. Ideal for facilities with multiple back pressure requirements as it is possible to stock one valve with several spare springs to cover a wide range of needs.
- **MK50H:** The MK50H features a handwheel that is mounted on the adjusting screw to allow easy setpoint changes.
- **MK50HP:** The MK50HP option is an elongated spring housing that features a large spring for high pressure setpoints up to 450 psi (31,03 bar).
- **MK50GP:** The MK50GP option is used in grain processing for starch cookers and other viscous services.
- **MK50CR:** The MK50CR option has a special spring housing for use if the valve is in cryogenic services.
- **MK501/502:** The MK501 and MK502 meet higher capacity requirements than standard back pressure regulators.
- **Sliding Gate Trim** — unique seat design for unsurpassed trim life and accuracy.
- **Jorcote Seat Coating** — ceramic composite for liquids, gases and especially steam. Very low friction with outstanding wear resistance. Steam tested to 1,000,000 cycles and still maintained Class IV leakage.
- **Jorlon Diaphragm** — extremely durable, virtually universally applicable up to 450°F, standard 316 SST diaphragm applicable up to 650°F. Tested without failure to over 1,000,000 full stroke cycles. Ideal for steam, gases and liquids.
- **Straight-through Flow** — The flow is straight through the valve seats and body. Direction of the disc travel is perpendicular to the flow, not opposed to the direction of the flow. Thus, the flow does not unbalance the seats. The MK50 can use a wider range of its stroke to give accurate control; less offset and rangeability up to 20:1.
- **Quiet Operation** — typically 5-10 dB less than conventional globe style regulators. The disc and plate are always in contact, which eliminates chattering. Straight-through flow minimizes turbulence. Multiple orifices in the plate and disc divide the flow stream into smaller flow components.
- **Minimum Maintenance** — The MK50 sliding gate seats require no special tools for disassembly. The seats are pre-lapped at the factory and are self-lapping while in operation ensuring a continual tight shutoff.



Jordan Valve, a division of Richards Industries
 3170 Wasson Road • Cincinnati, OH 45209
 513.533.5600 • 800.543.7311 • 513.871.0105 (f)
 info@richardsind.com • www.jordanvalve.com

MARK 50 SELF-OPERATING BACK PRESSURE REGULATORS

Mark 50 Series

Ideal for gas and liquids
Superior for steam

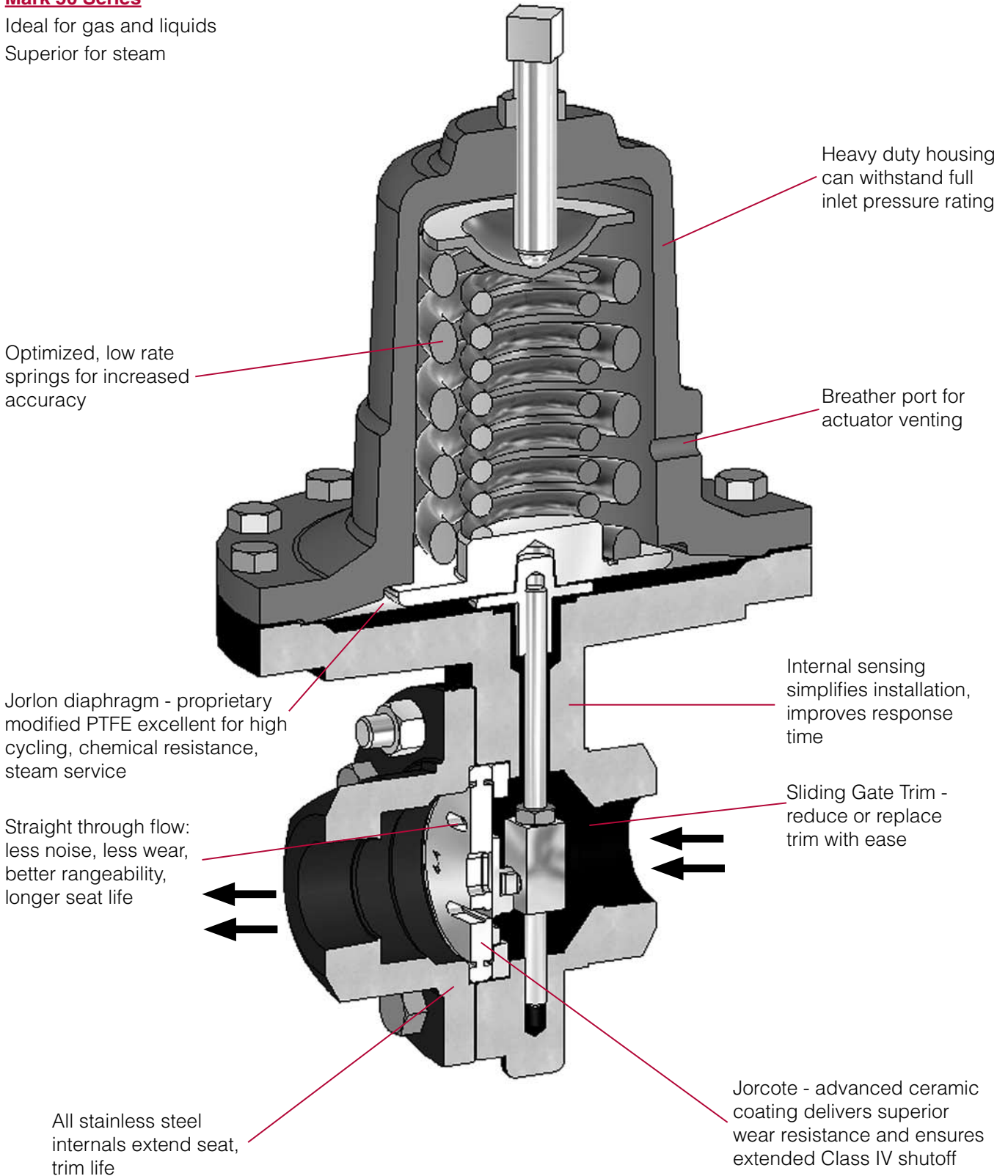

SPECIFICATIONS — MK50/50QC/51/50HP

- Sizes:** (1/4" & 3/8" sizes use 1/2" body with reducers)
- Mark 50: 1/4" through 4" (DN8 through DN100)
 - Mark 50QC: 1/4" through 2" (DN8 through DN50)
 - Mark 51: 1/4" through 3/4" (DN8 through DN20)
 - Mark 50HP: 1/4" through 4" (DN8 through DN100)

- End Connections:**
- Threaded — FNPT, BSPT, BSPP (1/2" - 2" only, DN15-DN50)
 - ANSI Flanges (150#, 300#, 600#)
 - DIN Flanges (PN10/16, PN25/40)
 - JIS Flanges (upon request)

- Spring Housing:**
- Ductile Iron — 1/4" - 2" (DN8 - DN50)
 - Ductile Iron — 2-1/2" - 4" (DN65 - DN100)

- Body Materials:**
- Ductile Iron
 - Bronze (1/2" - 2", DN15-DN50)
 - Carbon Steel (A216 WCB)
 - Stainless Steel (A351/CF8M)

- Trim Materials:**
- 303SST — Standard on Ductile Iron, Bronze, Carbon Steel valves
 - 316SST — Standard on Stainless Steel valves
 - Monel, Hastelloy and other Alloys available

Pressure Control Ranges: Select a range to match your setpoint. For optimal performance, your setpoint should fall in the upper portion of the selected range.

Model	Size (DN)	Spring Ranges	
		PSI	BAR
50 & 50QC	1/4" - 3/4" (DN8 - DN20)	2 - 20	0,14 - 1,38
		10 - 30	0,69 - 2,07
		20 - 45	1,38 - 3,10
		30 - 135	2,07 - 9,31
		80 - 185	5,52 - 12,76
	1" - 2" (DN25 - DN50)	1/2 - 4	0,03 - 0,28
		2 - 6	0,14 - 0,41
		4 - 13	0,28 - 0,90
		8 - 20	0,55 - 1,38
		15 - 80	1,03 - 5,52
	2-1/2" - 4" (DN65 - DN100)	45 - 150	3,10 - 10,34
		4 - 15	0,28 - 1,03
7 - 24		0,48 - 1,65	
50HP	1/2" - 2" (DN15 - DN40)	16 - 30	1,10 - 2,07
		75 - 190	5,17 - 13,10
		100 - 320	6,89 - 22,06
	2-1/2" - 4" (DN65 - DN100)	150 - 450	10,34 - 31,02
		25 - 50	1,72 - 3,45
51	1/4" - 3/4" (DN8 - DN20)	40 - 80	2,76 - 5,52
		1/2 - 5	0,03 - 0,34
		2 - 10	0,14 - 0,69
		2 - 20	0,14 - 1,38
		10 - 30	0,69 - 2,07
		20 - 50	1,38 - 3,45
		20 - 70	1,38 - 4,83
		40 - 105	2,76 - 7,24
		25 - 150	1,72 - 10,34
		30 - 170	2,07 - 11,72

- Seat Materials:**
- Jorcote on SST — Standard
 - Jorcote/Jordanic on SST — For Severe Service
 - Other materials available — Consult factory

- Diaphragm Materials:**
- Stainless Steel — Standard on 1/4" - 2" (DN8-DN50)
 - Buna-N — Standard on 2-1/2" - 4" (DN65-DN100)
 - Jorlon — On steam service 2-1/2" - 4" (DN65-DN100)
See page 12 of this brochure for details.
 - Viton — Optional

Service: Steam, water, oil, gas, air and chemicals

Shutoff: ANSI Class IV

- Options:**
- **Double Bolting:** improves the pressure rating of the valve and ensures a tight seal between the spring housing and the body for services with high inlet pressures.
 - **High Pressure Spring Housing:** the HP option is an elongated spring housing that features a large spring for high pressure setpoints (up to 450 psi/31bar).
 - **Handwheel:** the H option is a handwheel that is mounted on the adjusting screw to allow for easy setpoint changes.
 - **Exotic Alloys:** where service conditions dictate the use of specialty materials, the Mark 50 Series can be produced with bodies, trim and seats in Monel, Alloy 20, Hastelloy B, Hastelloy C, Titanium and others.
 - **GP Option:** grain processing modification for starch cookers and other viscous services.
 - **Cryogenic Service:** CR option is a special spring housing for use if valve is in cryogenic conditions.

Cv Values & Maximum Differential Pressures

Cv (Kv)	Size (DN)	Seat Material	Max. ΔP PSI (bar)
0.84 (0,74)	1/4" & 3/8" (DN8 & DN12)	SST	125 (8,62)
1.6 (1,38)		Jorcote	500 (37,92)
2.5 (2,15)	1/2" & 3/4" (DN15 & DN20)	SST	125 (8,62)
4.4 (3,78)		Jorcote	550 (37,92)
6.4 (5,50)	1" & 1-1/4" (DN25 & DN32)	SST	125 (8,62)
9.5 (8,17)		Jorcote	450 (31,03)
15 (12,9)	1-1/2" (DN40)	SST	75 (5,17)
		Jorcote	450 (31,03)
25 (21,5)	2" (DN50)	SST	75 (5,17)
30 (25,8)		Jorcote	450 (31,03)
55 (47,3)	2-1/2" (DN65)	Jorcote	150 (10,34)
115 (98,9)	3" (DN80)	Jorcote	150 (10,34)
200 (172)	4" (DN100)	Jorcote	150 (10,34)

Low Flow Cv's: reduced Cv's (Kv's) are available. Cv (Kv) ratings of smaller valves can be supplied in larger-sized valves.

0.42 (0,36)	0.21 (0,18)	0.08 (0,07)	0.04 (0,03)	0.02 (0,02)
0.008 (0,007)	0.004 (0,003)	0.002 (0,002)	0.0008 (0,0007) (N/A in 316SS)	

MARK 50 SELF-OPERATING BACK PRESSURE REGULATORS

Cv VERSUS BUILD-UP DATA

Model Mark 50 & 50QC							
Size NPS	Nominal Cv	Set Pressure	Cv @ 5% Build-Up	Cv @ 10% Build-Up	Cv @ 15% Build-Up	Cv @ 20% Build-Up	Cv @ 30% Build-Up
1/4" - 3/4"	1.6	20	0.25	0.38	0.52	0.64	0.85
		30	0.24	0.38	0.51	0.63	0.84
		45	0.26	0.40	0.54	0.67	0.91
		135	0.35	0.57	0.78	0.98	1.33
		185	0.35	0.58	0.79	1.00	1.37
	2.5	20	0.39	0.61	0.81	1.00	1.33
		30	0.38	0.59	0.79	0.98	1.32
		45	0.40	0.63	0.84	1.05	1.42
		135	0.54	0.89	1.22	1.53	2.08
		185	0.54	0.90	1.24	1.85	2.13
	4.4	20	0.69	1.07	1.42	1.76	2.35
		30	0.66	1.04	1.39	1.72	2.32
		45	0.70	1.11	1.48	1.85	2.49
		135	0.95	1.57	2.14	2.69	3.66
		185	0.95	1.59	2.17	2.74	3.75
1-1/4"	6.4	4	0.74	1.13	1.48	1.81	2.41
		6	0.75	1.17	1.54	1.90	2.53
		10	0.77	1.21	1.60	1.99	2.66
		20	0.76	1.17	1.57	1.95	2.65
		80	1.08	1.85	2.57	3.27	4.57
		150	1.63	2.96	4.24	5.50	6.40
	9.5	4	1.09	1.67	2.19	2.69	3.58
		6	1.11	1.73	2.29	2.82	3.75
		10	1.14	1.79	2.38	2.95	3.95
		20	1.12	1.74	2.33	2.90	3.93
		80	1.60	2.74	3.81	4.85	6.79
		150	2.42	4.39	6.30	8.16	9.50
1-1/2"	15	4	1.59	2.38	3.09	3.77	4.96
		6	1.61	2.46	3.22	3.93	5.20
		10	1.66	2.54	3.33	4.11	5.47
		20	1.63	2.47	3.27	4.04	5.45
		80	2.29	3.84	5.29	6.71	9.35
		150	3.42	6.10	8.70	11.20	15.00
2"	25	4	2.63	3.96	5.15	6.29	8.26
		6	2.70	4.09	5.36	6.56	8.66
		10	2.76	4.23	5.54	6.85	9.12
		20	2.72	4.12	5.45	6.74	9.09
		80	3.82	6.40	8.82	11.19	15.59
		150	5.69	10.16	14.50	18.72	25.00
	30	4	3.16	4.77	6.21	7.56	9.97
		6	3.24	4.93	6.45	7.90	10.44
		10	3.35	5.08	6.65	8.22	10.95
		20	3.26	4.95	6.54	8.09	10.90
		80	4.59	7.68	10.59	13.43	18.71
		150	6.83	12.19	17.40	22.46	30.00
2-1/4" - 4"	55	15	22.00	40.24	55.00	55.00	55.00
		20	16.69	30.13	43.17	55.00	55.00
		30	13.38	23.60	33.69	43.58	55.00
	115	15	40.26	73.10	104.44	115.00	115.00
		20	31.10	54.93	78.37	101.15	115.00
		30	24.70	43.21	61.34	79.11	113.36
	200	15	58.81	108.64	156.79	200.00	200.00
		20	44.01	80.90	116.68	151.45	200.00
		30	34.69	62.97	90.64	117.77	170.10

- Notes:
1. Installed Cv is the Failure Cv for Safety Relief Valve Sizing.
 2. Assumes SST diaphragm, optimal spring range for set point, and minimum flow = 5% of Cv.
 3. Shaded areas indicate valve reaches full Cv before offset is attained.

MARK 51 SELF-OPERATING BACK PRESSURE REGULATORS

Cv VERSUS BUILD-UP DATA

Model Mark 51							
Size NPS	Installed Cv	Set Pressure	Cv @ 5% Build-Up	Cv @ 10% Build-Up	Cv @ 15% Build-Up	Cv @ 20% Build-Up	Cv @ 30% Build-Up
1/4" - 3/4"	1.6	5	0.23	0.38	0.52	0.64	0.87
		10	0.28	0.47	0.64	0.79	1.08
		20	0.32	0.54	0.75	0.94	1.29
		30	0.35	0.59	0.84	1.06	1.46
		50	0.38	0.67	0.94	1.20	1.60
		80	0.45	0.80	1.15	1.47	1.60
		115	0.50	0.92	1.32	1.60	1.60
		160	0.70	1.32	1.60	1.60	1.60
		180	0.74	1.40	1.60	1.60	1.60
	2.5	5	0.36	0.60	0.81	1.00	1.36
		10	0.43	0.73	0.99	1.24	1.69
		20	0.49	0.84	1.17	1.47	2.01
		30	0.54	0.93	1.31	1.65	2.28
		50	0.60	1.04	1.47	1.88	2.50
		80	0.70	1.26	1.79	2.30	2.50
		115	0.78	1.43	2.06	2.50	2.50
		160	1.10	2.06	2.50	2.50	2.50
		180	1.16	2.19	2.50	2.50	2.50
	4.4	5	0.64	1.05	1.42	1.76	2.39
		10	0.76	1.28	1.75	2.18	2.98
		20	0.87	1.48	2.05	2.58	3.54
		30	0.96	1.63	2.30	2.91	4.01
		50	1.05	1.84	2.60	3.31	4.40
		80	1.23	2.21	3.15	4.05	4.40
		115	1.38	2.52	3.63	4.40	4.40
		160	1.93	3.62	4.40	4.40	4.40
		180	2.04	3.85	4.40	4.40	4.40

- Notes:
1. Installed Cv is the Failure Cv for Safety Relief Valve Sizing.
 2. Assumes SST diaphragm, optimal spring range for set point, and minimum flow = 5% of Cv.
 3. Shaded areas indicate valve reaches full Cv before offset is attained.

MARK 50 SELF-OPERATING BACK PRESSURE REGULATORS

MAXIMUM WORKING PRESSURE, PSI

MAXIMUM WORKING PRESSURE, BAR

Temp °F	1/4" - 2"					
	DI Body			BRZ Body		
	150#	300#	TE	150#	300#	TE
-20-100	250	300 (600)	300 (600)	225	300 (500)	300 (500)
200	235	300 (600)	300 (600)	215	300 (475)	300 (475)
300	215	300 (565)	300 (600)	195	300 (425)	300 (425)
400	200	300 (525)	300 (600)	170	300 (375)	300 (375)
500	170	300 (495)	300 (600)	150	300 (325)	300 (325)
600	140	300 (465)	300 (600)	—	—	—
650	125	300 (450)	300 (600)	—	—	—

Temp °C	DN8 - DN50					
	DI Body			BRZ Body		
	150#	300#	TE	150#	300#	TE
-29 to 38	17	21 (41)	21 (41)	16	21 (34)	21 (34)
93	16	21 (41)	21 (41)	15	21 (33)	21 (33)
149	15	21 (39)	21 (41)	13	21 (29)	21 (29)
204	14	21 (36)	21 (41)	12	21 (26)	21 (26)
260	12	21 (34)	21 (41)	10	21 (22)	21 (22)
316	10	21 (32)	21 (41)	—	—	—
343	9	21 (31)	21 (41)	—	—	—

Temp °F	1/4" - 2"					
	CS Body			SS Body		
	150#	300#	TE	150#	300#	TE
-20-100	285	300 (740)	300 (950)	275	300 (720)	300 (950)
200	260	300 (675)	300 (950)	240	300 (620)	300 (950)
300	230	300 (655)	300 (950)	215	300 (560)	300 (950)
400	200	300 (635)	300 (950)	195	300 (515)	300 (950)
500	170	300 (600)	300 (950)	170	300 (480)	300 (950)
600	140	300 (550)	300 (950)	140	300 (450)	300 (950)
650	125	300 (535)	300 (950)	125	300 (445)	300 (950)

Temp °C	DN8 - DN50					
	CS Body			SS Body		
	150#	300#	TE	150#	300#	TE
-29 to 38	20	21 (51)	21 (66)	19	21 (49)	21 (66)
93	18	21 (47)	21 (66)	17	21 (43)	21 (66)
149	16	21 (45)	21 (66)	15	21 (39)	21 (66)
204	14	21 (44)	21 (66)	13	21 (36)	21 (66)
260	12	21 (41)	21 (66)	12	21 (33)	21 (66)
316	10	21 (38)	21 (66)	10	21 (31)	21 (62)
343	9	21 (37)	21 (66)	9	21 (31)	21 (61)

Temp °F	2-1/4" - 4"					
	DI Body		CS Body		SS Body	
	150#	300#	150#	300#	150#	300#
-20 to 100	250	500	285	500	275	500
200	235	500	260	500	240	500
300	215	500	230	500	215	500
400	200	500	200	500	195	500
500	170	495	170	500	170	500
600	140	300	140	300	140	300
650	125	300	125	300	125	300

Temp °C	DN65 - DN100					
	DI Body		CS Body		SS Body	
	150#	300#	150#	300#	150#	300#
-29 to 38	17	34	20	34	19	34
93	16	34	18	34	17	34
149	15	34	16	34	15	34
204	4	34	14	34	13	34
260	12	34	12	34	12	34
316	10	21	10	21	10	21
343	9	21	9	21	9	21

Temp °F	50 HP Series (1/2" - 2")	
	CS Body	SS Body
	600# Flange or NPT	600# Flange or NPT
100	1480	1440
200	1355	1240
300	1315	1120
400	1270	1030
500	1208	955
600	1095	905
650	1075	890

Temp °C	50 HP Series (DN15 - DN50)	
	CS Body	SS Body
	600# Flange or NPT	600# Flange or NPT
38	102	99
93	93	85
149	91	77
204	88	71
260	83	66
316	75	62
343	74	61

Notes:

1. Double bolting option is required to reach pressures indicated in parentheses ().
2. If weld flanges are supplied, use ratings in "TE" column or flange rating, whichever is less (i.e. ANSI 600/900 flanges or PN64/100 flanges).

DIMENSIONS — MK50/MK50QC

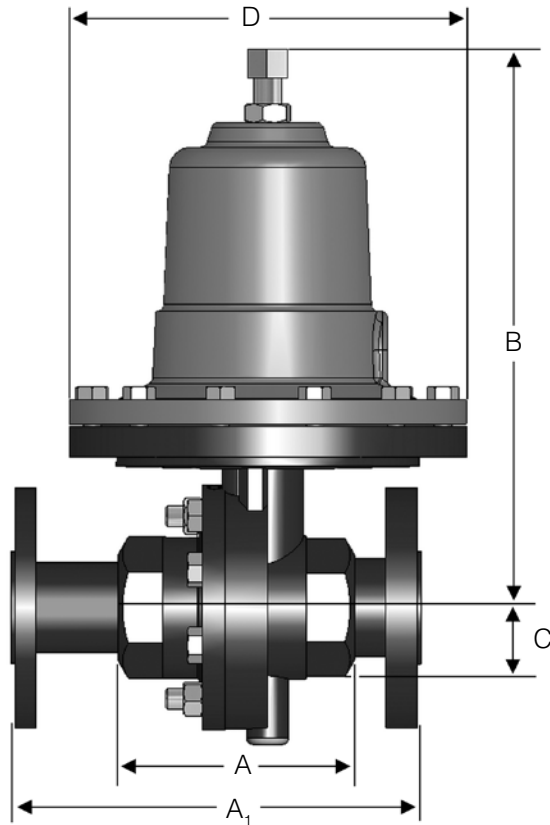

• Mark 50 / Mark 50QC*: Threaded & FSW Ends

Size	Mat'l	Dimensions (inches)					Weight (lbs.)
		A	B	B~QC	C	D	
1/2" & 3/4"	DI/BRZ	3.62	8.50	10.25	1.69	5.12	10
	CS/SS	3.62	8.50	10.25	1.69	5.12	12
1"	DI/BRZ	4.12	10.00	11.37	2.62	7.09	21
	CS/SS	4.18	10.75	12.00	2.63	7.09	25
1-1/4"	DI/BRZ	4.12	10.00	11.37	2.62	7.09	21
1-1/2"	DI/BRZ	4.50	10.25	11.37	2.31	7.09	23
	CS/SS	4.81	11.00	12.25	2.25	7.09	31
2"	DI/BRZ	4.50	10.25	11.37	2.75	7.09	26
	CS/SS	5.50	11.00	12.25	2.75	7.09	35

* For MK50QC, use column B~QC.

• Mark 50 / Mark 50QC*: Threaded & FSW Ends, Metric

Size	Mat'l	Dimensions					Wgt. (kg)
		A	B	B~QC	C	D	
DN15 & 20	DI/BRZ	91,95	215,90	260,35	42,93	130,05	4,5
	CS/SS	91,95	215,90	260,35	42,93	130,05	5,4
DN25	DI/BRZ	104,65	254,00	288,80	66,55	180,09	9,5
	CS/SS	106,17	273,05	304,80	66,55	180,09	11,3
DN32	DI/BRZ	104,65	254,00	288,80	66,55	180,09	9,5
DN40	DI/BRZ	114,30	260,35	288,80	58,67	180,09	10,4
	CS/SS	122,17	279,40	311,15	57,15	180,09	14,1
DN50	DI/BRZ	114,30	260,35	288,80	69,85	180,09	11,8
	CS/SS	139,70	279,40	311,15	69,85	180,09	15,9

* For MK50QC, use column B~QC.

MARK 50 SELF-OPERATING BACK PRESSURE REGULATORS

DIMENSIONS — MK50

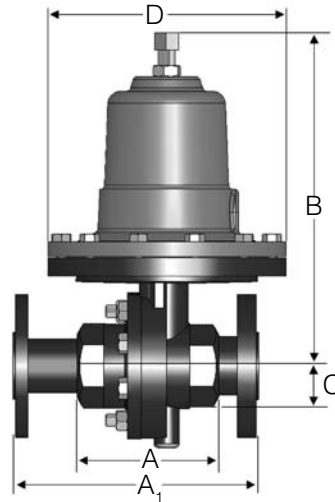

- Mark 50: Integral Flanges - ANSI, CS & SS Bodies

Size	ANSI Flange	Dimensions (inches)						Weight (lbs.)	
		A1		B		C	D	DI/BRZ	CS/SS
		DI/BRZ	CS/SS	DI/BRZ	CS/SS	All	All		
1/2"	150#	7.25	7.25	8.50	8.50	1.69	5.12	13	15
	300#	7.50	7.50	8.50	8.50	1.69	5.12	14	16
3/4"	150#	7.25	7.25	8.50	8.50	1.69	5.12	14	16
	300#	7.62	7.62	8.50	8.50	1.69	5.12	16	17
1"	150#	7.25 ¹	7.25 ²	10.0	10.75	2.62	7.09	26	34
	300#	8.75 ¹	7.75 ²	10.0	10.75	2.62	7.09	28	37
1 1/4"	150#	7.87	—	10.0	—	2.62	7.09	28	—
	300#	8.37	—	10.0	—	2.62	7.09	31	—
1 1/2"	150#	8.75 ¹	8.75 ²	10.25	11.22	2.31	7.09	42	46
	300#	10.25 ¹	9.25 ²	10.25	11.22	2.31	7.09	45	52
2"	150#	10.0	10.0	10.25	11.42	2.75	7.09	46	50
	300#	10.5	10.5	10.25	11.42	2.75	7.09	49	55

Note: Dimensions for 2-1/2" to 4" sizes apply to DI bodies also.

¹ Not ANSI Standard, ² IFE only

- Mark 50: Integral Flanges - Metric

Size (DN)	Flange (PN)	Dimensions						Weight (kg)	
		A1		B		C	D	DI/BRZ	CS/SS
		DI/BRZ	CS/SS	DI/BRZ	CS/SS	All	All		
15	10/16	184,2	184,2	215,9	215,9	42,9	130	5,9	5,9
	25/40	190,5	190,5	215,9	215,9	42,9	130	6,4	6,4
20	10/16	184,5	184,2	215,9	215,9	42,9	130	6,4	6,4
	25/40	193,5	193,5	215,9	215,9	42,9	130	7,3	7,7
25	10/16	184,2 ¹	184,2 ²	254,0	273,1	66,5	180	11,8	15,4
	25/40	223,1 ¹	196,9	254,0	273,1	66,5	180	12,7	16,8
32	10/16	199,9	—	254,0	—	66,5	180	12,7	—
	25/40	212,6	—	254,0	—	66,5	180	14,1	—
40	10/16	222,3 ¹	222,3 ²	260,4	285,0	58,7	180	19,1	20,9
	25/40	260,3 ¹	235,0 ²	260,4	285,0	58,7	180	20,4	23,6
50	10/16	254,0	254,0	260,4	290,1	69,9	180	20,9	22,7
	25/40	266,7	266,7	260,4	290,1	69,9	180	22,2	24,9

Note: Dimensions for DN65 to DN80 sizes apply to DI bodies also.

¹ Not ANSI Standard, ² IFE only

- Mark 50: Companion Flanges - ANSI, Ductile & Bronze Bodies

Size	Flange	Dimensions (inches)				Weight (lbs.)
		A	B	C	D	
1/2"	150#	7.25	8.50	1.75	5.12	13
	300#	7.50	8.50	1.87	5.12	14
3/4"	150#	7.25	8.50	1.93	5.12	14
	300#	7.62	8.50	2.31	5.12	16
1"	150#	7.25	10.00	2.12	7.09	26
	300#	8.75	10.00	2.43	7.09	28
1-1/4"	150#	7.87	10.00	2.31	7.09	28
	300#	8.37	10.00	2.62	7.09	31
1-1/2"	150#	8.75	10.25	2.50	7.09	42
	300#	10.25	10.25	3.06	7.09	45
2"	150#	10.00	10.25	3.00	7.09	46
	300#	10.50	10.25	3.25	7.09	49

- Mark 50: Companion Flanges - ANSI, Ductile & Bronze Bodies - Metric

Size (DN)	Flange (PN)	Dimensions				Weight (kg)
		A	B	C	D	
15	10/16	184,2	215,9	44,5	130	5,9
	25/40	190,5	215,9	47,5	130	6,4
20	10/16	184,4	215,9	49,0	130	6,4
	25/40	193,5	215,9	58,7	130	7,3
25	10/16	184,2	254,0	53,8	180	11,8
	25/40	222,3	254,0	61,7	180	12,7
32	10/16	199,9	254,0	58,7	180	12,7
	25/40	212,6	254,0	66,5	180	14,1
40	10/16	222,3	260,4	63,5	180	19,1
	25/40	260,3	260,4	77,7	180	20,4
50	10/16	254,0	260,4	76,2	180	20,9
	25/40	266,7	260,4	82,6	180	22,2

MARK 50 SELF-OPERATING BACK PRESSURE REGULATORS

DIMENSIONS — MK50

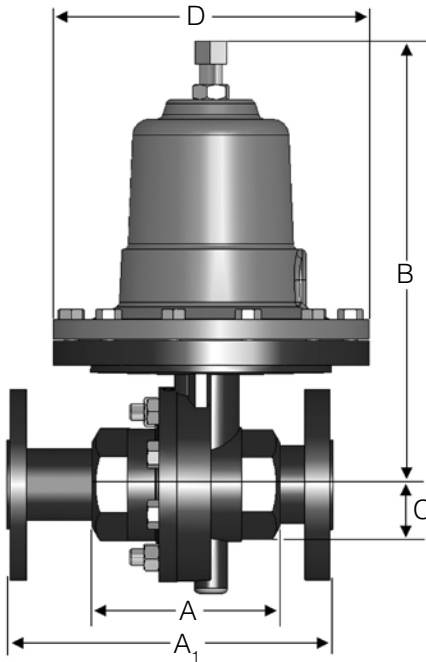

• Mark 50: Flanged Ends, ANSI

Size	ANSI Flange	Dimensions (inches)						Weight (lbs.)	
		A1		B		C	D	DI/BRZ	CS/SS
		DI/BRZ	CS/SS	DI/BRZ	CS/SS	All	All		
1/2"	150#	7.25	7.25	8.50	8.50	1.69	5.12	13	15
	300#	7.50	7.50	8.50	8.50	1.69	5.12	14	16
3/4"	150#	7.25	7.25	8.50	8.50	1.69	5.12	14	16
	300#	7.62	7.62	8.50	8.50	1.69	5.12	16	17
1"	150#	7.25	7.25	10.0	10.75	2.62	7.09	26	34
	300#	8.75 ¹	7.75 ²	10.00	10.75	2.62	7.09	28	37
1 1/4"	150#	7.87	—	10.00	—	2.62	7.09	31	—
	300#	8.37	—	10.00	—	2.62	7.09	31	—
1 1/2"	150#	8.75	8.75	10.25	11.22	2.31	7.09	42	46
	300#	10.25 ¹	9.25 ²	10.25	11.22	2.31	7.09	45	52
2"	150#	10.00	10.00	10.25	11.42	2.75	7.09	46	50
	300#	10.50	10.50	10.25	11.42	2.75	7.09	49	55
Flanged Ends CS/SS									
Larger Sizes		A	B	C	D	Weight (lbs.)			
2-1/2"	125-150#	10.88	18.75	6.95	12.75	165			
	250-300#	11.50	18.75	6.95	12.75	165			
3"	125-150#	11.75	18.75	6.95	12.75	185			
	250-300#	12.50	18.75	6.95	12.75	185			
4"	125-150#	13.88	19.95	8.00	12.75	215			
	250-300#	14.50	19.95	8.00	12.75	215			

1. Not ANSI Standard.
2. IFE only.

• Mark 50: Flanged Ends, Metric

Size DN	Flange PN	Dimensions (mm)						Weight (kg)	
		A1		B		C	D	DI/BRZ	CS/SS
		DI/BRZ	CS/SS	DI/BRZ	CS/SS	All	All		
15	10/16	184	130	216	240	43	130	5,9	6,8
	25/40	184	130	216	240	43	130	6,4	7,3
20	10/16	184	150	216	240	43	130	6,4	7,3
	25/40	184	150	216	240	43	130	7,3	7,7
25	10/16	184	160	273	262	67	180	11,8	15,4
	25/40	184	160	273	262	67	180	12,7	16,8
32	10/16	200	—	273	—	67	180	12,7	—
	25/40	200	—	273	—	67	180	4,1	—
40	10/16	222	200	279	285	59	180	19,1	20,9
	25/40	222	200	279	285	59	180	20,4	23,6
50	10/16	254	230	279	290	70	180	20,9	22,7
	25/40	254	230	279	290	70	180	22,2	24,9
Flanged Ends CS/SS									
Larger Sizes		A	B	C	D	Weight (kg)			
65	10/16	283	476	177	324	75			
	25/40	283	476	177	324	75			
80	10/16	312	476	177	324	84			
	25/40	312	476	177	324	84			
100	10/16	350	507	203	324	98			
	25/40	350	507	203	324	98			

1. Smaller sizes A1 not IFE and not per DIN 3202.
2. Larger sizes A not per DIN 3202.

MARK 50HP SELF-OPERATING BACK PRESSURE REGULATORS

DIMENSIONS — MK50HP

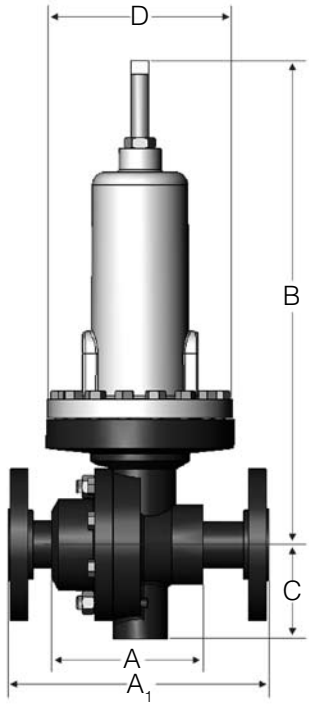

• Mark 50HP: Flanged Ends

Size	Flange	Dimensions (inches)					Weight (lbs.)
		A1		B†	C	D	
		DI/BRZ	CS/SS	All	All	All	
1/2"	150#	7.25	7.25	12.25	1.69	5.20	21
	300#	7.50	7.50	12.25	1.69	5.20	
	600#‡	8.00	8.00	12.25	1.69	5.20	
3/4"	150#	7.25	7.25	12.25	1.69	5.20	22
	300#	7.62	7.62	12.25	1.69	5.20	
	600#‡	8.12	8.12	12.25	1.69	5.20	
1"	150#	7.25	7.25	12.75	2.62	5.20	37
	300#	7.75	7.75	12.75	2.62	5.20	
	600#‡	8.25	8.25	12.75	2.62	5.20	
1-1/4"	150#	7.87	—	12.75	2.62	5.20	37
	300#	8.37	—	12.75	2.62	5.20	
1-1/2"	150#	8.75	8.75	13.25	2.31	5.20	45
	300#	9.25	9.25	13.25	2.31	5.20	
	600#‡	9.87	9.87	13.25	2.31	5.20	
2"	150#	10.00	10.00	13.50	2.75	5.20	49
	300#	10.50	10.50	13.50	2.75	5.20	
	600#‡	11.25	11.25	13.50	2.75	5.20	

† For IFE, add 1" (25,4mm) to all "B" dimensions.

‡ 600# are not IFE

• Mark 50HP: Threaded & FSW Ends

Size	Mat'l	Dimensions (inches)				Weight (lbs.)
		A	B	C	D	
1/2" & 3/4"	DI/BRZ	3.62	12.25	1.75	5.12	15
	CS/SS	3.62	12.25	1.75	5.12	17
1"	DI/BRZ	4.12	12.50	2.12	5.20	21
	CS/SS	4.18	12.75	2.12	5.20	25
1-1/4"	DI/BRZ	4.12	12.50	2.12	5.20	21
1-1/2"	DI/BRZ	4.50	12.75	2.31	5.20	23
	CS/SS	4.81	13.25	2.50	5.20	31
2"	DI/BRZ	4.50	12.75	2.50	5.20	26
	CS/SS	5.50	13.50	2.50	5.20	35

• Mark 50HP: Threaded & FSW Ends, Metric

Size (DN)	Mat'l	Dimensions				Weight (kg)
		A	B	C	D	
15 & 20	DI/BRZ	92,0	311,2	44,5	130,0	6,8
	CS/SS	92,0	311,2	44,5	130,0	7,7
25	DI/BRZ	104,7	317,5	53,9	132,1	9,5
	CS/SS	106,2	323,9	53,9	132,1	11,3
32	DI/BRZ	104,7	317,5	53,9	132,1	9,5
40	DI/BRZ	114,3	323,9	58,7	132,1	10,4
	CS/SS	122,2	336,6	63,5	132,1	14,1
50	DI/BRZ	114,3	323,9	63,5	132,1	11,8
	CS/SS	139,7	342,9	63,5	132,1	15,9

• Mark 50HP: Flanged Ends, Metric³

Size (DN)	Flange PN	Dimensions (mm)					Weight (kg)
		A1		B ²	C	D	
		DI/BRZ ¹	CS/SS	All	All	All	
15	10/16	184,2	130,0	311,2	42,9	132,1	9,5
	25/40	184,2	130,0	311,2	42,9	132,1	
20	10/16	184,2	150,0	311,2	42,9	132,1	10,0
	25/40	184,2	150,0	311,2	42,9	132,1	
25	10/16	184,2	160,0	323,9	66,6	132,1	16,8
	25/40	184,2	160,0	323,9	66,6	132,1	
32	10/16	199,9	—	323,9	66,6	132,1	16,8
	25/40	199,9	—	323,9	66,6	132,1	
40	10/16	222,3	200,0	336,6	58,7	132,1	20,4
	25/40	222,3	200,0	336,6	58,7	132,1	
50	10/16	254,0	230,0	342,9	69,9	132,1	22,2
	25/40	254,0	230,0	342,9	69,9	132,1	

1. Not IFE & not per DIN3202

2. For IFE, add 25,4mm.

3. For DIN flanges above PN40, please consult factory.

DIMENSIONS — MK51

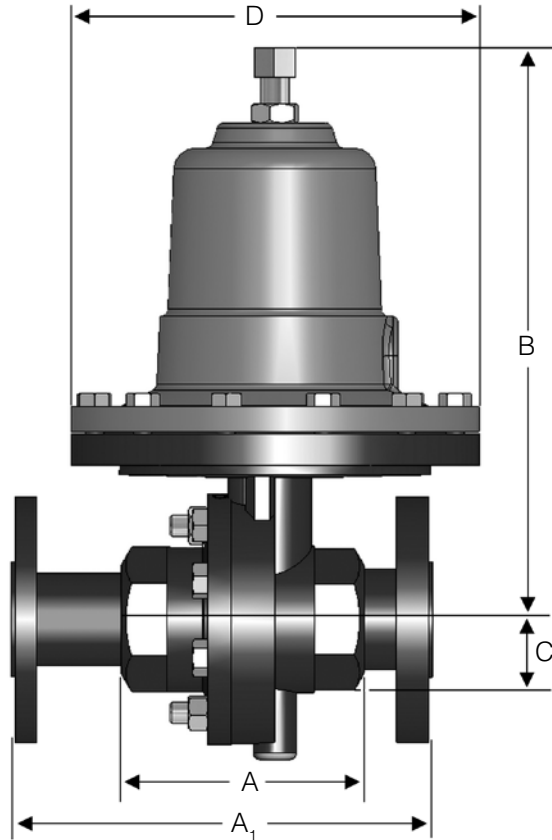

• Mark 51: Threaded & FSW Ends

Size	Material	Dimensions (inches)				Weight (lbs.)
		A	B	C	D	
1/2" & 3/4"	DI/BRZ	3.62	10.25	2.25	7.12	12
	CS/SS	3.62	10.25	2.25	7.12	13

• Mark 51, Flanged Ends

Size	ANSI Flange	Dimensions (inches)						Weight (lbs.)	
		A1		B		C	D	DI/BRZ	CS/SS
		DI/BRZ	CS/SS	DI/BRZ	CS/SS	All	All		
1/2" & 3/4"	150#	9.62	9.62	10.25	10.25	2.25	7.12	26	26
	300#	10.25	10.25	10.25	10.25	2.25	7.12	29	29

• Mark 51: Threaded & FSW Ends, Metric

Size (DN)	Material	Dimensions (mm)				Weight (kg)
		A	B	C	D	
15 & 20	DI/BRZ	92,0	260,4	57,2	180,9	5,4
	CS/SS	92,0	260,4	57,2	180,9	5,9

• Mark 51, Flanged Ends, Metric

Size (DN)	Flange PN	Dimensions (mm)						Weight (kg)	
		A1 ¹		B		C	D	DI/BRZ	CS/SS
		DI/BRZ	CS/SS	DI/BRZ	CS/SS	All	All		
15 & 20	10/16	244,4	244,4	260,4	260,4	57,2	180,9	11,8	11,8
	25/40	260,4	260,4	260,4	260,4	57,2	180,9	13,2	13,2

Note: 1/4" & 3/8" utilize 1/2" body with reducer bushings.

The Jorlon Diaphragm - Revolutionary Diaphragm Sets New Standard

- **Easily retrofitted** — Jorlon can be easily retrofitted in the field with no additional parts. For regulators purchased after the fall of 1991, only the diaphragm needs to be changed to retrofit either SST or elastomer diaphragms.
- **Chemical Compatibility** — Jorlon is PTFE based, so it is compatible with most media except fluorinated gases and halogenated fluorocarbons. Whether the application is steam, process gases or fluids, Jorlon should be your first choice.
- **Improved Build-up Performance** — A metal diaphragm is much more rigid than an elastomer diaphragm. As such, metal diaphragms have decreased sensitivity thereby diminishing performance and accuracy in a self operated regulator. Jorlon will improve droop performance when used instead of a SST diaphragm as its properties are more similar to those of elastomer materials.
- **Less Expensive** — Jorlon is less expensive than many other diaphragm materials, further increasing its customer value.
- **Fast Delivery** — Rely on our 36 hour delivery with Jorlon as the diaphragm material.
- **Extremely Long Life** — Under 300 psi air, Jorlon surpasses 1,000,000 full stroke cycles without failure. The harshest test was on 450°F saturated steam, where Jorlon exceeded the cycle count for stainless steel by over 150 times - the test was stopped and the Jorlon diaphragm had yet to fail.
- **Lower Cost of Ownership** — Less droop provides more accuracy, improving efficiency and productivity. Extremely long life results in more production up-time, fewer spare parts expenses and less repair labor.

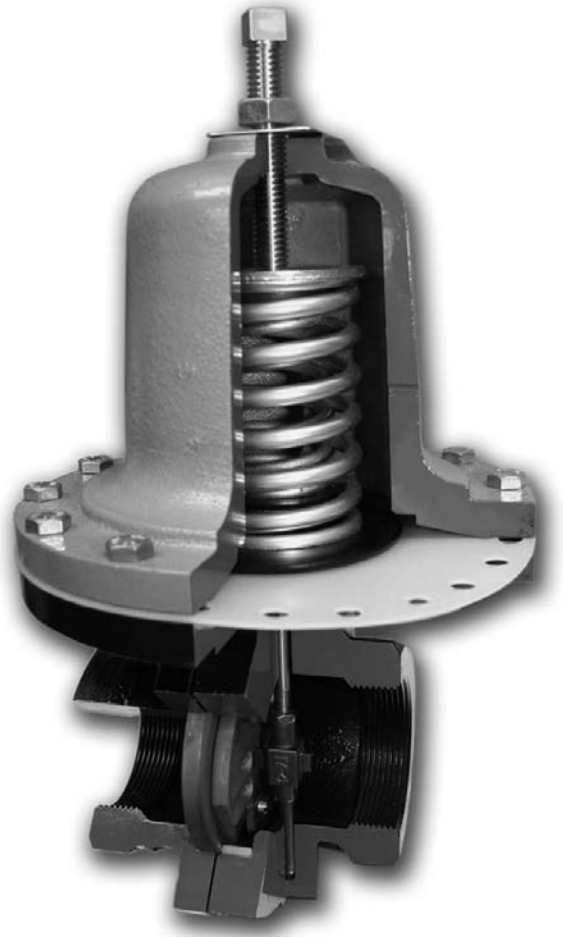

MARK 50 SELF-OPERATING BACK PRESSURE REGULATORS

ORDERING SCHEMATIC

1		2		3	/	4	5	6	7	8	9	10

1	Model		
50	Standard		
50HP	High Pressure		
50QC	Quick Change		
51	Large Diaphragm		

2	Size			
	Inches (DN)		Inches (DN)	
025	1/4" (DN8)	150	1-1/2" (DN40)	
038	3/8" (DN10)	200	2" (DN50)	
050	1/2" (DN15)	250	2-1/2" (DN65) (MK50/50HP only)	
075	3/4" (DN20)	300	3" (DN80) (MK50/50HP only)	
100	1" (DN25)	400	4" (DN100) (MK50/50HP only)	

MK51 available in 1/4" through 3/4" only.

3	Body Material	
DI	Ductile Iron	
BR	Bronze (1/4" - 2")	
CS	Carbon Steel	
S6	Stainless Steel	
CI	Cast Iron (2-1/2" - 4")	

4	End Connections	
	MK50/51, 1/4" - 2"	
PT	NPT	
BT	BSPT	
BP	BSPP	
SW	FSW	
I5	150# IFE	
F5	150# FE (except IFE)	
I3	300# IFE	
F3	300# FE (except IFE)	
MK50, 2-1/2" - 4"		
I1	125# IFE	
I5	150# IFE	
I2	250# IFE	
I3	300# IFE	
I7	PN 10 DIN IFE (CS/S6) DN15-150	
I6	PN 16 DIN IFE (CS/S6) DN15-150	
I8	PN 25 DIN IFE (CS/S6) DN15-150	
I4	PN 40 DIN IFE (CS/S6) DN15-150	

5	Trim		
S3	303SS	I3	303SSF/IFE (1" - 2")
S6	316SS	I6	316SSF/IFE (1" - 2")

6	Seat Material		
A	303SST (1/4" - 2")	W	316SS/Jorcote
B	316SST (1/4" - 2")	X	303SS/Jorcote/Jordanic
V	303SS/Jorcote	Y	316SS/Jorcote/Jordanic

7	Cv (Kv)			
1	0.21 (0,28)	9	15 (12,93)	
2	0.42 (0,36)	A	25 (21,55)	
3	0.84 (0,72)	B	30 (25,86)	
4	1.6 (1,38)	D*	55 (47,41)	
5	2.5 (2,16)	F*	85 (73,28)	
6	4.4 (3,79)	G*	115 (99,14)	
7	6.4 (5,52)	I*	200 (172,41)	
8	9.5 (8,19)	* 2-1/2" - 4" only		

8	MK50/50QC Spring Range PSI (BAR)				
		1/4" - 3/4"	1" - 2"	2-1/2" - 4"	
14	2-20 (0,14-1,38)	03	1/2-4 (0,03-0,28)	22	4-15 (0,28-1,3)
34	10-30 (0,69-2,07)	06	2-6 (0,14-0,41)		
53	20-45 (1,38-3,10)	21	4-13 (0,28-0,90)	30	7-24 (0,48-1,65)
76	30-135 (2,07-9,31)	31	8-20 (0,55-1,38)		
A4	80-185 (5,52-12,76)	50	15-80 (1,3-5,52)	52	16-30 (1,10-2,07)
		95	45-150 (3,10-10,34)		

8	MK50HP Spring Range PSI (BAR)		
		1/2" - 2"	2-1/2" - 4"
A1	75-190 (5,17-13,10)	64	25-50 (1,72-3,45)
A7	100-320 (6,89-22,06)	82	40-80 (2,76-5,52)
A9	150-450 (10,34-31,02)		

8	MK51 Spring Range PSI (BAR)		
04	1/2-5 (0,03-0,34)	62	20-70 (1,38-4,83)
08	2-10 (0,14-0,69)	86	40-105 (2,76-7,24)
14	2-20 (0,14-1,38)	69	25-150 (1,72-10,34)
34	10-30 (0,69-2,07)	79	30-170 (2,07-11,72)
54	20-50 (1,38-3,45)		

9	Diaphragm	
S6	316 SST (1/4" - 2" only)	
VI	Viton	
BN	Buna-N (standard above 2"/DN50)	
JL	Jorlon	

10	Actuator	
MD	for Metal Diaphragm (1/4" - 2" only)	
ED	for Elastomer Diaphragm	

Mark 501/502 Series

High Flow Back Pressure Regulators

The Mark 501 and 502 meet higher capacity requirements than standard back pressure regulators. The High Flow Mark 501 has Cv's as high as 50 (43Kv) and the Super High Flow Mark 502 has Cv's up to 70 (60,2 Kv). Each valve is standard with Jordan's Sliding Gate Seats, which helps to reduce the build-up commonly associated with high flow back pressure regulators.

Jordan's unique self-operated sliding gate back pressure regulator offers:

Shorter stroke than a globe or plug-style valve

- Faster response
- Smaller and lighter weight than globe-style valves
- Less build-up

Straight through flow

- Less turbulence, erosion and noise
- Improved rangeability
- Longer seat life

Ease of maintenance

- Interchangeable seats and Cv's
- Fewer spare parts
- Self-cleaning seats
- No gaskets or o-rings

SPECIFICATIONS

Sizes: 1-1/2" & 2" (DN40 & DN50)

End Connections:

- Threaded (FNPT, BSPT, BSPP)
- ANSI Flanges (150#, 300#)
- DIN Flanges (PN10/16, PN25/40)

Body Materials: Ductile Iron, Bronze, Carbon Steel (A216 WCB), Stainless Steel (A351/CF8M)

Trim Materials:

- 303SST — Standard on Ductile Iron, Bronze, Carbon Steel valves
- 316SST — Standard on Stainless Steel Valves
- Monel, Hastelloy and other Alloys available
-

Seat Materials:

- Jorcote on SST — Standard
- Jorcote/Jordanic on SST — For Severe Service



Diaphragm Materials:

- Stainless Steel — standard
- Buna-N — optional
- Jorlon — optional
- Viton — optional

Service: Steam, water, oil, gas, air and chemicals

Shutoff: ANSI Class IV

Reduced Pressure Control Ranges: Select a range to match your setpoint. For optimal performance, your setpoint should fall in the upper portion of the selected range.

Model	Size (DN)	Spring Ranges	
		PSI	BAR
501 & 502	1-1/2" - 2" (DN40 - DN50)	0.5 - 4	0,03 - 0,28
		2 - 6	0,14 - 0,41
		4 - 13	0,28 - 0,90
		8 - 20	0,55 - 1,38
		15 - 80	1,03 - 5,52
		45 - 150	3,10 - 10,34

Cv Values & Maximum Differential Pressures

- Mark 501

Cv (Kv)	Size (DN)	Seat Material	Maximum ΔPSI (bar)
25 (21,5)	1-1/2" & 2" (DN40 & DN50)	Jorcote	150 (10,34)
30 (25,8)	1-1/2" & 2" (DN40 & DN50)	Jorcote	150 (10,34)
35 (30,1)	1-1/2" & 2" (DN40 & DN50)	Jorcote	150 (10,34)
45 (38,7)	1-1/2" (DN40)	Jorcote	150 (10,34)
50 (43,0)	2" (DN50)	Jorcote	150 (10,34)

- Mark 502

Cv (Kv)	Size (DN)	Seat Material	Maximum ΔPSI (bar)
65 (55,9)	1-1/2" (DN40)	Jorcote	150 (10,34)
70 (60,2)	2" (DN50)	Jorcote	150 (10,34)



Jordan Valve, a division of Richards Industries

3170 Wasson Road • Cincinnati, OH 45209
513.533.5600 • 800.543.7311 • 513.871.0105 (f)
info@richardsind.com • www.jordanvalve.com

DIMENSIONS — MK501/502

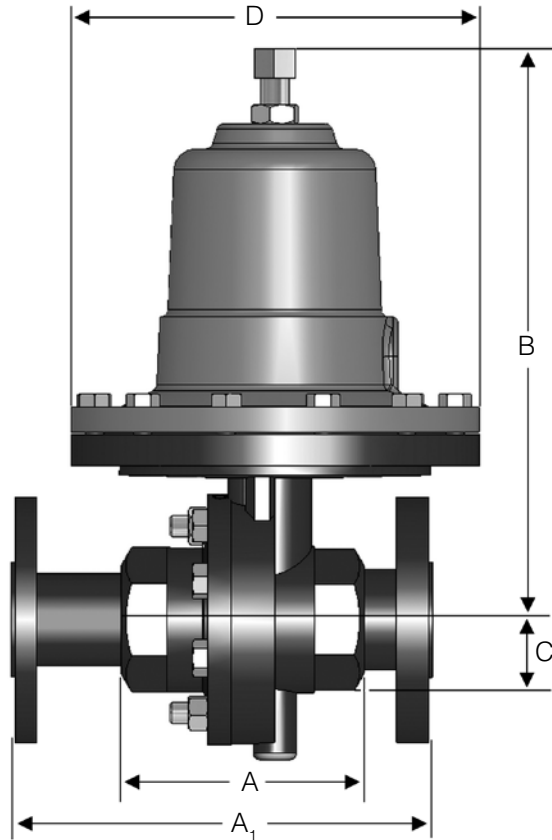

- Mark 501/502: Threaded & FSW Ends

Size	Material	Dimensions (inches)				Weight (lbs.)
		A	B	C	D	
1-1/2" - 2"	DI/BRZ	4.50	10.25	2.75	7.09	26
	CS/SS	5.50	11.00	2.75	7.09	35

- Mark 501/502: Threaded & FSW Ends, Metric

Size (DN)	Material	Dimensions (mm)				Weight (kg)
		A	B	C	D	
40 - 50	DI/BRZ	114	260	70	180	11,8
	CS/SS	140	279	70	180	15,9

- Mark 501/502, Flanged Ends

Size	ANSI Flange	Dimensions (inches)						Weight (lbs.)	
		A1		B		C	D	DI/BRZ	CS/SS
		DI/BRZ	CS/SS	DI/BRZ	CS/SS	All	All		
1-1/2"	150#	10.00*	10.00*	10.25	11.22	2.31	7.09	42	46
	300#	10.25*	10.25*	10.25	11.22	2.31	7.09	45	52
2"	150#	10.00	10.00	10.25	11.42	2.75	7.09	46	50
	300#	10.50	10.50	10.25	11.42	2.75	7.09	49	55

* Not IFE. Not ANSI Standard.

- Mark 501/502, Flanged Ends, Metric

Size (DN)	Flange PN	Dimensions (mm)						Weight (kg)	
		A1		B		C	D	DI/BRZ	CS/SS
		DI/BRZ	CS/SS	DI/BRZ	CS/SS	All	All		
40	10/16	254	254	279	285	58,7	180	19,1	20,9
	25/40	260	260	279	285	58,7	180	20,4	23,6
50	10/16	254	230	279	290	69,9	180	20,9	22,7
	25/40	267	230	279	290	69,9	180	22,2	24,9

ORDERING SCHEMATIC

1	—	2	—	3	/	4	5	6	7	8	9	10	11	12
----------	---	----------	---	----------	---	----------	----------	----------	----------	----------	----------	-----------	-----------	-----------

1	Model	
501	High Flow	
502	Super High Flow	

2	Size	
	Inches (DN)	
150	1-1/2" (DN40)	
200	2" (DN50)	

3	Body Material	
DI	Ductile Iron	
BR	Bronze	
CS	Carbon Steel	
S6	Stainless Steel	

4	End Connections	
PT	NPT	
BT	BSPT	
I5	150# IFE CS or SST*	
F5	150# FE DI or BR	
I7	PN10 IFE CS or SST*	
F7	PN10 FE DI or BR	
I6	PN16 IFE CS or SST*	
F6	PN16 FE DI or BR	
BP	BSPP	
SW	FSW	
I3	300# IFE CS or SST*	
F3	300# FE DI or BR	
I8	PN25 IFE CS or SST*	
F8	PN25 FE DI or BR	
I4	PN40 IFE CS or SST*	
F4	PN40 FE DI or BR	

* IFE (integral flanged end) for 2" only.
FE is threaded or weld flanges.

5	Trim	
S3	303SS	
S6	316SS	
I3	303SSF/IFE	
I6	316SSF/IFE	

6	Seat Material	
V	303SS/Jorcote	
W	316SS/Jorcote	
X	303SS/Jorcote/Jordanic	
Y	316SS/Jorcote/Jordanic	

7	Cv (Kv)	
A	25 (22)	
B	30 (26)	
V	35 (30)	
W	45 (39)	
C	50 (43)	
Y	65 (56)	
E	70 (60)	

8	Range	
03	0.5 - 4 (0,03 - 0,28)	
06	2 - 6 (0,14 - 0,41)	
21	4 - 13 (0,28 - 0,90)	
31	8 - 20 (0,55 - 1,38)	
50	15 - 80 (1,03 - 5,52)	
95	45 - 150 (3,10 - 10,34)	

9	Diaphragm	
S6	316 SST	
VI	Viton	
BN	Buna-N	
JL	Jorlon	

10	Actuator	
MD	for Metal Diaphragm	
ED	for Elastomer Diaphragm	

11	Double Boltin	
00	None	
ZZ	Non-Standard	

12	Accessories	
0	None	
6	316 SS Bolting	
7	Hi-Temperature Bolting	
Z	Non-Standard	

