

Mark 60 Series

Self-Operated Pressure Regulators

The MK60 Sliding Gate Pressure Regulator is used to regulate the downstream pressure to a predetermined setpoint. The spring in the Mark 60 holds the sliding gate seats in their normally open position to allow the process media to pass through the seats.

The downstream pressure is sensed beneath the diaphragm. As the downstream pressure exceeds the setpoint, pressure is exerted on the diaphragm which raises the stem to modulate the disc (the moveable component on the sliding gate seat set) toward the closed position. As the seats close, downstream pressure will be reduced to the required setpoint. A decrease in pressure relaxes the spring and diaphragm to move the seats toward the open position.

This brochure includes the following Series:

- **MK60:** a line of self-operating pressure regulators designed with Jordan Valve's sliding gate seats
- **MK61:** The MK61 features a larger diaphragm than a standard MK60 to provide even greater sensitivity and minimal offset from a required setpoint
- **MK60QC:** The MK60QC features a "Quick Change" dome for simple range spring replacements. Ideal for facilities with multiple pressure reducing applications - stock one valve with several spare springs to cover a wide range of needs
- **MK60H:** The MK60H features a handwheel that replaces the adjusting screw for easy changes to the setpoint
- **MK60HP:** Working pressure fully rated to ANSI Class 600 pressures, the HP options permits setpoints as high as 450 psi
- **MK60GP:** The MK60GP option requires grain processing modification for starch cookers and other viscous services
- **MK601/602:** The MK601 and MK602 meet higher capacity requirements than standard regulators



MARK 60 FEATURES

- **Sliding Gate Trim** — unique seat design for unsurpassed trim life and accuracy.
- **Jorcote Seat Coating** — ceramic composite for liquids, gases and especially steam. Very low friction with outstanding wear resistance. Steam tested to 1,000,000 cycles and still maintained Class IV leakage.
- **Jorlon Diaphragm** — extremely durable, virtually universally applicable up to 450°F, standard 316 SST diaphragm applicable up to 650°F. Tested without failure to over 1,000,000 full stroke cycles. Ideal for steam, gases and liquids.
- **Straight-through Flow** — The flow is straight through the valve seats and body. Direction of the disc travel is perpendicular to the flow, not opposed to the direction of the flow. Thus, the flow does not unbalance the seats. The MK60 can use a wider range of its stroke to give accurate control; less offset.
- **Quiet Operation** — typically 5-10 dB less than conventional globe style regulators. The disc and plate are always in contact, which eliminates chattering. Straight-through flow minimizes turbulence. Multiple orifices in the plate and disc divide the flow stream into smaller flow components.
- **Minimum Maintenance** — The MK60 sliding gate seats require no special tools for disassembly. The seats are pre-lapped at the factory and are self-lapping while in operation ensuring a continual tight shutoff.



Jordan Valve, a Division of Richards Industries

3170 Wasson Road • Cincinnati, Ohio 45209

Telephone 513-533-5600 • Fax 513-871-0105

Toll-Free Telephone: 800-543-7311 (U. S. A. & Canada)

E-Mail: info@richardsind.com • URL: www.jordanvalve.com

Mark 60 Series

Ideal for gas and liquids
Superior for steam

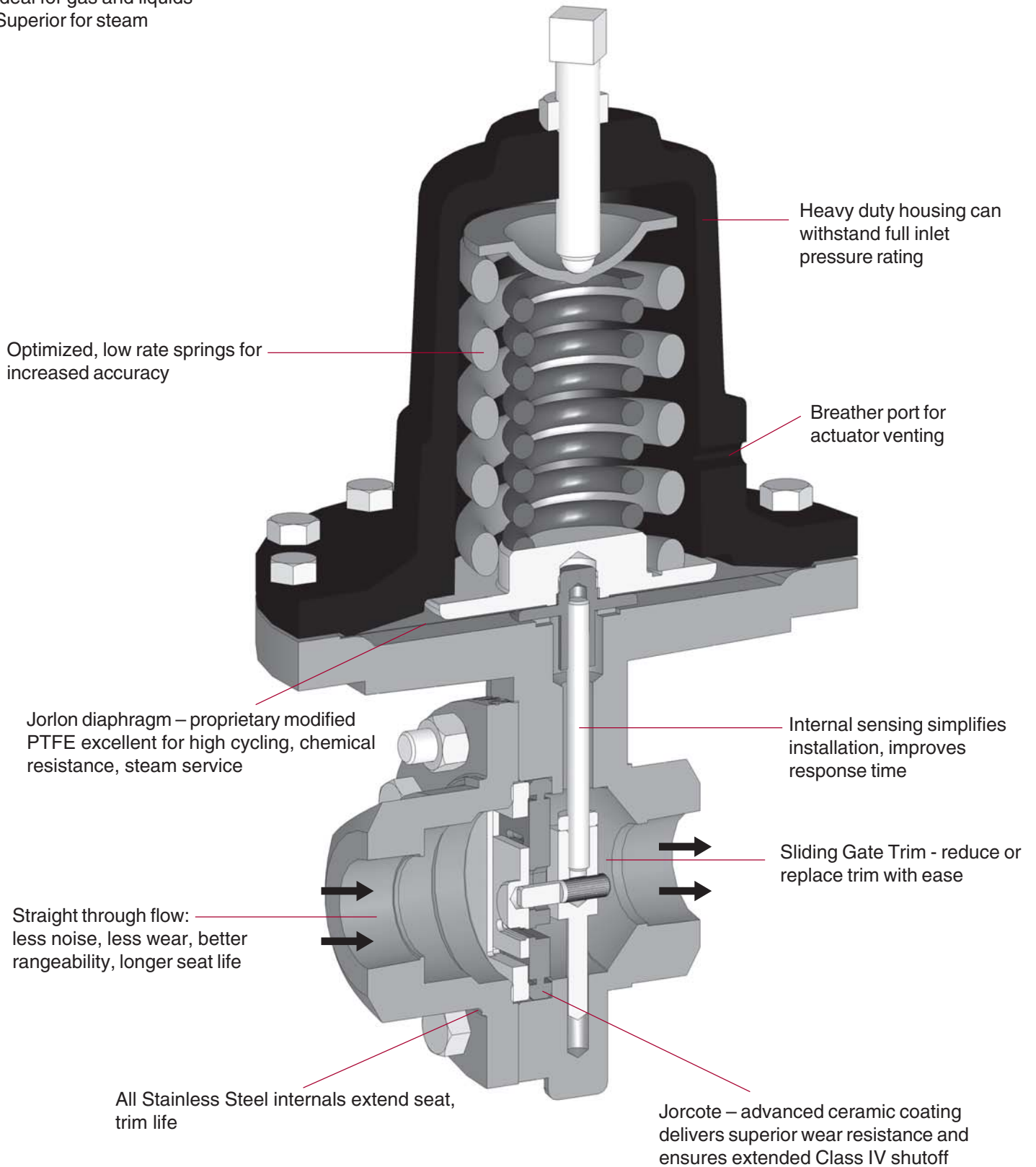

SPECIFICATIONS — MK60/60QC/61/60HP

Sizes: (note: 1/4" & 3/8" sizes use 1/2" body with reducers)

- Mark 60: 1/4" through 4" (DN8 through DN100)
- Mark 60QC: 1/4" through 2" (DN8 through DN50)
- Mark 61: 1/4" through 3/4" (DN8 through DN20)
- Mark 60HP: 1/4" through 4" (DN8 through DN100)

End Connections

- Threaded — FNPT, BSPT, BSPP (1/2" - 2" only, DN15-DN50)
- ANSI Flanges (150#, 300#)
- DIN Flanges (PN10/16, PN25/40)

Spring Housing

- CI or DI — 1/4" through 2" (DN8 through DN50)
- DI/Steel — 2-1/2" through 4" (DN65 through DN100)

Body Materials

- Ductile Iron
- Bronze (1/2" - 2", DN15 through DN50)
- Carbon Steel (A216 WCB)
- Stainless Steel (A351/CF8M)

Trim Materials:

- 303SST — Standard on Ductile Iron, Bronze, Carbon Steel valves
- 316SST — Standard on Stainless Steel valves
- Monel, Hastelloy and other Alloys available

Reduced Pressure Control Ranges: Select a range to match your setpoint. For optimal performance, your setpoint should fall in the upper portion of the selected range.

Model	Size (DN)	Spring Ranges	
		PSI	BAR
60 & 60QC	1/4" - 3/4" (DN8 - DN20)	2 - 23	0,14 - 1,59
		10 - 38	0,69 - 2,62
		20 - 55	1,38 - 3,79
		30 - 85	2,07 - 5,86
		35 - 160	2,41 - 11,03
	1" - 2" (DN25 - DN50)	95 - 220	6,55 - 15,17
		1 - 5	0,07 - 0,34
		3 - 8	0,21 - 0,55
		5 - 20	0,34 - 1,38
		10 - 30	0,69 - 2,07
		20 - 45	1,38 - 3,10
	2-1/2" - 4" (DN65 - DN100)	30 - 95	2,07 - 6,55
		60 - 160	4,14 - 11,03
		7 - 18	0,48 - 1,24
		10 - 25	0,69 - 1,72
60HP	1/2" - 2" (DN15 - DN40)	15 - 35	1,03 - 2,41
		75 - 190	5,17 - 13,10
		100 - 320	6,89 - 22,06
	2-1/2" - 4" (DN65 - DN100)	150 - 450	10,34 - 31,02
		30 - 75	3,07 - 5,17
61	1/4" - 3/4" (DN8 - DN20)	65 - 110	4,48 - 7,58
		1 - 5	0,07 - 0,34
		2 - 12	0,14 - 0,83
		2 - 25	0,14 - 1,72
		10 - 35	0,69 - 2,41
		20 - 55	1,38 - 3,79
		20 - 80	1,38 - 5,52
		40 - 115	2,76 - 7,93
		25 - 160	1,72 - 11,03
		30 - 180	2,07 - 12,41

Seat Materials:

- Jorcote on SST — Standard
- Jorcote/Jordanic on SST — For Severe Service
- Other materials available — Consult Factory

Diaphragm Materials:

- Stainless Steel — Standard on 1/4" - 2" (DN8-DN50)
- Jorlon — 1/2" - 4" (DN15-DN100) ideal for steam up to 400 psi
- Buna-N — Standard on 2-1/2" - 4" (DN65-DN100)
- Viton — Optional

Service: Steam, water, oil, gas, air and chemicals

Shutoff: ANSI Class IV

Options:

- **Double Bolting:** increases the pressure rating of the valve and ensures a tight seal between the spring housing and the body for services with high inlet pressures
- **High Pressure Spring Housing:** the HP option is an elongated spring housing that features a large spring for high pressure setpoints (up to 450 psi/31bar)
- **Handwheel:** the H option is a handwheel that is mounted on the adjusting screw to allow for easy setpoint changes
- **Exotic Alloys:** where service conditions dictate the use of specialty materials, the Mark 60 Series can be produced with bodies, trim and seats in Monel, Alloy 20, Hastelloy B, Hastelloy C, Titanium and others
- **GP Option:** grain processing modification for starch cookers and other viscous services. Available on Stainless Steel valves in 1/4" - 2" sizes only (DN8 - DN50)
- **Cryogenic Service:** CR option is a special spring housing for use if valve is in cryogenic service

CV Values & Maximum Differential Pressures

Cv (Kv)	Size (DN)	Seat Material	Maximum ΔP PSI (bar)
0.84 (0,74)	1/4" & 3/8" (DN8 & 12)	SST	125 (8,62)
1.6 (1,38)		Jorcote	400 (27,58)
2.5 (2,15)	1/2" & 3/4" (DN15 & 20)	SST	125 (8,62)
4.4 (3,78)		Jorcote	400 (27,58)
6.4 (5,50)	1" & 1-1/4" (DN25 & 32)	SST	125 (8,62)
9.5 (8,17)		Jorcote	400 (27,58)
15 (12,9)	1-1/2" (DN40)	SST	75 (5,17)
		Jorcote	325 (22,41)
25 (21,5)	2" (DN50)	SST	75 (5,17)
30 (25,8)		Jorcote	325 (22,41)
55 (47,3)	2-1/2" (DN65)	Jorcote	150 (10,34)
115 (98,9)	3" (DN80)	Jorcote	150 (10,34)
200 (172)	4" (DN100)	Jorcote	150 (10,34)

Low Flow Cv's: reduced Cv's (Kv's) are available. Cv (Kv) ratings of smaller sized valve can be supplied in a larger valve size

0.42 (0,36)	0.21 (0,18)	0.08 (0,07)	0.04 (0,03)	0.02 (0,02)
0.008 (0,007)	0.004 (0,003)	0.002 (0,002)	0.0008 (0,0007) (N/A in 316SS)	

MK60 SELF-OPERATING PRESSURE REGULATORS

Cv VERSUS OFFSET DATA

Model Mark 60 & 60QC								
Size NPS	Installed Cv	Set Pressure	Cv @ 5% Offset	Cv @ 10% Offset	Cv @ 15% Offset	CV @ 20% Offset	Cv @ 30% Offset	
1/4" - 3/4"	1.6	25	0.21	0.34	0.49	0.65	1.02	
		35	0.24	0.38	0.53	0.69	1.06	
		55	0.31	0.46	0.63	0.82	1.25	
		160	0.79	1.11	1.50	1.60	1.60	
		220	1.00	1.60	1.60	1.60	1.60	
	2.5	20	0.33	0.49	0.76	0.96	1.54	
		35	0.38	0.55	0.83	1.03	1.60	
		55	0.48	0.68	0.99	1.23	1.82	
		160	1.23	1.68	2.27	2.50	2.50	
		220	1.58	2.12	2.50	2.50	2.50	
	4.4	20	0.58	0.94	1.34	1.78	2.81	
		35	0.67	1.05	1.45	1.90	2.91	
		55	0.84	1.28	1.74	2.25	3.43	
		160	2.16	3.04	4.00	4.40	4.40	
		220	2.79	3.81	4.40	4.40	4.40	
1" - 1-1/4"	6.4	5	0.72	0.99	1.29	1.62	2.41	
		8	0.77	1.09	1.44	1.83	2.75	
		30	0.92	1.36	1.83	2.34	3.48	
		45	0.99	1.48	2.00	2.56	3.80	
		95	1.36	2.14	2.96	3.83	5.74	
		160	1.92	3.14	4.41	5.74	6.40	
	9.5	5	1.06	1.46	1.91	2.41	3.58	
		8	1.15	1.62	2.14	2.72	4.08	
		30	1.37	2.02	2.72	3.47	5.12	
		45	1.47	2.20	2.98	3.80	5.64	
		95	2.01	3.17	4.40	5.69	8.52	
		160	2.85	4.66	6.54	8.53	9.50	
	1-1/2"	15	5	1.55	2.11	2.72	3.40	5.02
			8	1.67	2.32	3.03	3.82	5.69
			30	1.97	2.86	3.82	4.85	7.17
45			2.10	3.10	4.16	5.30	7.81	
95			2.84	4.42	6.10	7.87	11.71	
160			3.98	6.44	9.02	11.73	15.00	
2"	25	5	2.86	3.95	5.15	6.50	9.70	
		8	3.09	4.37	5.79	8.21	11.07	
		30	3.69	5.46	7.37	9.42	14.04	
		45	3.96	5.95	8.07	10.33	15.34	
		95	5.45	8.60	11.94	15.47	23.20	
		160	7.74	12.65	17.81	23.2	25.00	
	30	5	3.11	4.21	5.43	6.79	10.04	
		8	3.34	4.64	6.06	7.65	11.39	
		30	3.93	5.72	7.64	9.70	14.34	
		45	4.20	6.20	8.33	10.60	15.62	
		95	5.69	8.85	12.19	15.73	23.48	
		160	7.97	12.89	18.04	23.45	30.00	
	2-1/4" - 4"	55	17	11.72	21.47	32.08	43.68	55.00
			25	10.92	19.67	29.08	39.23	55.00
			35	9.83	17.31	25.22	33.59	51.92
115		18	21.92	39.47	58.58	79.48	115.00	
		25	20.46	36.23	53.17	71.44	112.61	
		35	18.50	31.96	46.20	61.29	94.30	
200		18	34.71	61.53	90.74	122.68	196.40	
		25	32.47	56.57	82.47	110.39	173.29	
			35	29.48	20.05	71.81	94.85	145.29

Notes:

1. Installed Cv is the Failure Cv for Safety Relief Valve Sizing
2. Assumes SST diaphragm, optimal spring range for set point, and minimum flow = 5% of Cv
3. Indicates valve reaches full Cv before offset is attained
4. Offset: also known as "droop", inaccuracy or deviation from setpoint is an inherent characteristic of self-operated regulators. Many factors affect and determine offset. Spring rate, diaphragm area and stroke length are three key factors. The short stroke of the SLIDING GATE design helps minimize droop. These tables can be used to estimate performance of the MK60 regulator.

Cv VERSUS OFFSET DATA

Model Mark 61							
Size NPS	Installed Cv	Set Pressure	Cv @ 5% Offset	Cv @ 10% Offset	Cv @ 15% Offset	CV @ 20% Offset	Cv @ 30% Offset
1/4" - 3/4"	1.6	5	0.23	0.33	0.44	0.56	0.86
		12	0.29	0.44	0.60	0.78	1.21
		25	0.36	0.56	0.78	1.03	1.60
		35	0.39	0.63	0.88	1.16	1.60
		55	0.44	0.71	1.00	1.31	1.60
		80	0.49	0.81	1.14	1.51	1.60
		115	0.56	0.92	1.30	1.60	1.60
		160	0.75	1.27	1.60	1.60	1.60
	180	0.79	1.33	1.60	1.60	1.60	
	2.5	5	0.36	0.51	0.69	0.88	1.34
		12	0.45	0.68	0.93	1.22	1.89
		25	0.56	0.87	1.22	1.61	2.50
		35	0.62	0.98	1.38	1.82	2.50
		55	0.68	1.10	1.56	2.05	2.50
		80	0.77	1.26	1.78	2.34	2.50
		115	0.87	1.44	2.03	2.50	2.50
		160	1.18	1.98	2.50	2.50	2.50
	180	1.24	2.07	2.50	2.50	2.50	
	4.4	5	0.63	0.90	1.21	1.55	2.35
		12	0.79	1.20	1.64	2.14	3.32
		25	0.98	1.54	2.15	2.83	4.40
		35	1.08	1.73	2.43	3.20	4.40
		55	1.21	1.94	2.74	3.61	4.40
		80	1.36	2.22	3.13	4.12	4.40
115		1.54	2.53	3.57	4.40	4.40	
160		2.07	3.48	4.40	4.40	4.40	
180	2.18	3.65	4.40	4.40	4.40		

Notes:

1. Installed Cv is the Maximum Cv for Safety Relief Valve Sizing
2. Assumes SST diaphragm, optimal spring range for set point, and minimum flow = 5% of Cv
3. Indicates valve reaches full Cv before offset is attained

MAXIMUM WORKING PRESSURE, PSI

MAXIMUM WORKING PRESSURE, BAR

Temp °F	1/4" - 2"					
	DI Body			BRZ Body		
	150#	300#	TE	150#	300#	TE
-20 to 100	250	300 [600]	300 [600]	225	300 [500]	300 [500]
200	235	300 [600]	300 [600]	215	300 [475]	300 [475]
300	215	300 [565]	300 [600]	195	300 [425]	300 [425]
400	200	300 [525]	300 [600]	170	300 [375]	300 [375]
500	170	300 [495]	300 [600]	150	300 [325]	300 [325]
600	140	300 [465]	300 [600]	—	—	—
650	125	300 [450]	300 [600]	—	—	—

Temp °C	DN8 - DN50					
	DI Body			BRZ Body		
	150#	300#	TE	150#	300#	TE
-29 to 38	17	21 [41]	21 [41]	16	21 [34]	21 [34]
93	16	21 [41]	21 [41]	15	21 [33]	21 [33]
149	15	21 [39]	21 [41]	13	21 [29]	21 [29]
204	14	21 [36]	21 [41]	12	21 [26]	21 [26]
260	12	21 [34]	21 [41]	10	21 [22]	21 [22]
316	10	21 [32]	21 [41]	—	—	—
343	9	21 [31]	21 [41]	—	—	—

Temp °F	1/4" - 2"					
	CS Body			SS Body		
	150#	300#	TE	150#	300#	TE
-20 to 100	285	300 [740]	300 [950]	275	300 [720]	300 [950]
200	260	300 [675]	300 [950]	240	300 [620]	300 [950]
300	230	300 [655]	300 [950]	215	300 [560]	300 [950]
400	200	300 [635]	300 [950]	195	300 [515]	300 [950]
500	170	300 [600]	300 [950]	170	300 [480]	300 [950]
600	140	300 [550]	300 [950]	140	300 [450]	300 [905]
650	125	300 [535]	300 [950]	125	300 [445]	300 [890]

Temp °C	DN8 - DN50					
	CS Body			SS Body		
	150#	300#	TE	150#	300#	TE
-29 to 38	20	21 [51]	21 [66]	19	21 [49]	21 [66]
93	18	21 [47]	21 [66]	17	21 [43]	21 [66]
149	16	21 [45]	21 [66]	15	21 [39]	21 [66]
204	14	21 [44]	21 [66]	13	21 [36]	21 [66]
260	12	21 [41]	21 [66]	12	21 [33]	21 [66]
316	10	21 [38]	21 [66]	10	21 [31]	21 [62]
343	9	21 [37]	21 [66]	9	21 [31]	21 [61]

Temp °F	2-1/2" - 4"					
	DI Body		CS Body		SS Body	
	150#	300#	150#	300#	150#	300#
-20 to 100	250	500	285	500	275	500
200	235	500	260	500	240	500
300	215	500	230	500	215	500
400	200	500	200	500	195	500
500	170	495	170	500	170	500
600	140	300	140	300	140	300
650	125	300	125	300	125	300

Temp °C	DN65- DN100					
	DI Body		CS Body		SS Body	
	150#	300#	150#	300#	150#	300#
-29 to 38	17	34	20	34	19	34
93	16	34	18	34	17	34
149	15	34	16	34	15	34
204	4	34	14	34	13	34
260	12	34	12	34	12	34
316	10	21	10	21	10	21
343	9	21	9	21	9	21

Temp °F	60 HP Series (1/2" - 2")	
	CS Body	SS Body
	600# Flange or NPT	600# Flange or NPT
100	1480	1440
200	1355	1240
300	1315	1120
400	1270	1030
500	1208	955
600	1095	905
650	1075	890

Temp °C	60 HP Series (DN15-50)	
	CS Body	SS Body
	600# Flange or NPT	600# Flange or NPT
38	102	99
93	93	85
149	91	77
204	88	71
260	83	66
316	75	62
343	74	61

Notes:

- 1 Double bolting option is required to reach pressures indicated in Brackets [].
- 2 If weld flanges are supplied, use ratings in "TE" column or flange rating, whichever is less (i.e. ANSI 600/900 flanges or PN64/100 flanges).
- 3 Consult factory for availability of ANSI/DIN/JIS flanges not indicated above.

DIMENSIONS — MK60/MK60QC

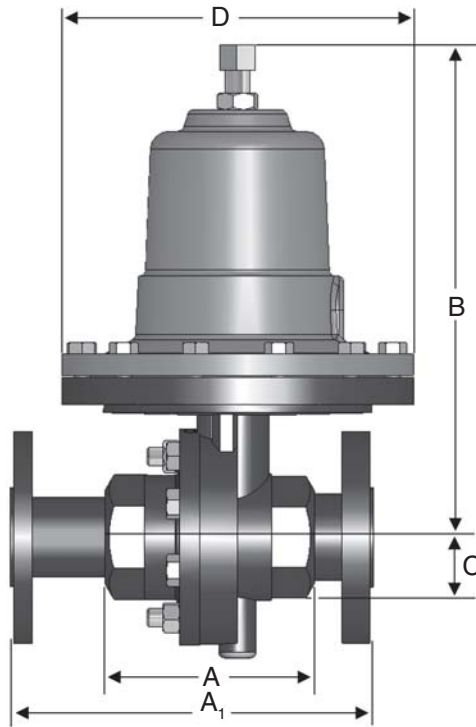

■ Mark 60/MK60QC*: Threaded & FSW Ends

Size	Material	A	B	B-QC	C	D	Weight (lbs)
1/2"	DI/BRZ	3.62"	8.50"	10.25"	1.69"	5.12"	10
	CS/SS	3.62"	8.50"	10.25"	1.69"	5.12"	12
3/4"	DI/BRZ	3.62"	8.50"	10.25"	1.69"	5.12"	10
	CS/SS	3.62"	8.50"	10.25"	1.69"	5.12"	12
1"	DI/BRZ	4.12"	10.00"	11.37"	2.62"	7.09"	21
	CS/SS	4.18"	10.75"	12.00"	2.62"	7.09"	25
1-1/4"	DI/BRZ	4.12"	10.00"	11.37"	2.62"	7.09"	21
1-1/2"	DI/BRZ	4.50"	10.25"	11.37"	2.31"	7.09"	23
	CS/SS	4.81"	11.00"	12.25"	2.25"	7.09"	31
2"	DI/BRZ	4.50"	10.25"	11.37"	2.75"	7.09"	26
	CS/SS	5.50"	11.00"	12.25"	2.75"	7.09"	35

*For MK60QC, use Column B-QC

■ Mark 60/MK60QC: Threaded & FSW Ends, Metric

Size	Material	A	B	C	D	Weight (kg)
DN15	DI/BRZ	92	216	43	130	4,4
	CS/SS	92	216	43	130	5,4
DN20	DI/BRZ	92	216	43	130	4,5
	CS/SS	92	216	43	130	5,4
DN25	DI/BRZ	105	254	67	180	9,5
	CS/SS	106	273	67	180	11,3
DN32	DI/BRZ	105	254	67	180	9,5
DN40	DI/BRZ	114	260	59	180	10,4
	CS/SS	122	279	57	180	14,0
DN50	DI/BRZ	114	260	70	180	11,8
	CS/SS	140	279	70	180	15,9

*For MK60QC, use Column B-QC

DIMENSIONS — MK60

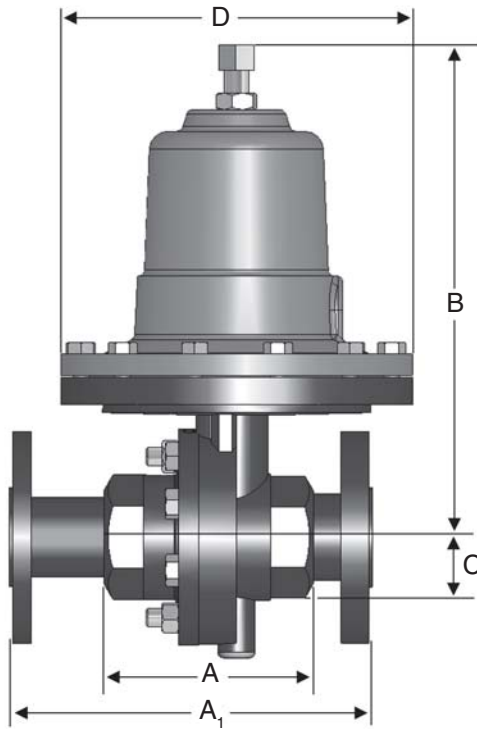

■ Mark 60: Flanged Ends, ANSI

Size	ANSI Flange	Dimensions (in)						Weight (lbs)	
		A1		B		C	D	DI/BRZ	CS/SS
		DI/BRZ	CS/SS	DI/BRZ	CS/SS	ALL	ALL		
1/2"	150#	7.25	7.25	8.50	8.50	1.69	5.12	13	15
	300#	7.50	7.50	8.50	8.50	1.69	5.12	14	16
3/4"	150#	7.25	7.25	8.50	8.50	1.69	5.12	14	16
	300#	7.62	7.62	8.50	8.50	1.69	5.12	16	17
1"	150#	7.25	7.25	10.00	10.75	2.62	7.09	26	34
	300#	8.75 ¹	7.75 ²	10.00	10.75	2.62	7.09	28	37
1-1/4"	150#	7.87	—	10.00	—	2.62	7.09	28	—
	300#	8.37	—	10.00	—	2.62	7.09	31	—
1-1/2"	150#	8.75	8.75	10.25	11.22	2.31	7.09	42	46
	300#	10.25 ¹	9.25 ²	10.25	11.22	2.31	7.09	45	52
2"	150#	10.00	10.00	10.25	11.42	2.75	7.09	46	50
	300#	10.50	10.50	10.25	11.42	2.75	7.09	49	55
Flanged End CS/SS									
Larger sizes		A	B	C	D	Weight (lbs)			
2-1/2"	125-150#	10.88	18.75	6.95	12.75	165			
	250-300#	11.50	18.75	6.95	12.75	165			
3"	125-150#	11.75	18.75	6.95	12.75	185			
	250-300#	12.50	18.75	6.95	12.75	185			
4"	125-150#	13.88	19.95	8.00	12.75	215			
	250-300#	14.50	19.95	8.00	12.75	215			

1 Not ANSI standard
2 IFE only

■ Mark 60: Flanged Ends, Metric

Size DN	ANSI Flange	Dimensions (in)						Weight (kgs)	
		A1		B		C	D	DI/BRZ	CS/SS
		DI/BRZ	CS/SS	DI/BRZ	CS/SS	ALL	ALL		
15	10/16	184	130	216	240	43	130	5,9	6,8
	25/40	184	130	216	240	43	130	6,4	7,3
20	10/16	184	150	216	240	43	130	6,4	7,3
	25/40	184	150	216	240	43	130	7,3	7,7
25	10/16	222	160	273	262	67	180	11,8	15,4
	25/40	222	160	273	262	67	180	12,7	16,8
32	10/16	222	—	273	—	67	180	12,7	—
	25/40	222	—	273	—	67	180	14,1	—
40	10/16	222	200	279	285	59	180	19,1	20,9
	25/40	222	200	279	285	59	180	20,4	23,6
50	10/16	254	230	279	290	70	180	20,9	22,7
	25/40	254	230	279	290	70	180	22,2	24,9
Flanged End CS/SS									
Larger sizes		A	B	C	D	Weight (kgs)			
65	10-16	283	476	177	324	75			
	25-40	283	476	177	324	75			
80	10-16	312	476	177	324	84			
	25-40	312	476	177	324	84			
100	10-16	350	507	203	324	98			
	25-40	350	507	203	324	98			

Smaller sizes A1 not IFE & not per DIN3202
Larger sizes A not per DIN3202

DIMENSIONS — MK60HP

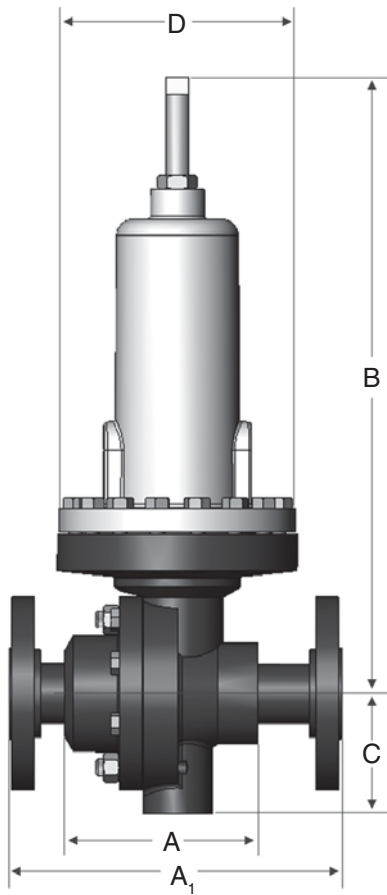

■ Mark 60HP: Threaded & FSW Ends

Size	Material	A	B	C	D	Weight (lbs)
1/2" & 3/4"	DI/BRZ	3.62"	12.25"	1.75"	5.12"	15
	CS/SS	3.62"	12.25"	1.75"	5.12"	17
1"	DI/BRZ	4.12"	12.50"	2.12"	5.20"	21
	CS/SS	4.18"	12.75"	2.12"	5.20"	25
1-1/4"	DI/BRZ	4.12"	12.50"	2.12"	5.20"	21
1-1/2"	DI/BRZ	4.50"	12.75"	2.31"	5.20"	23
	CS/SS	4.81"	13.25"	2.50"	5.20"	31
2"	DI/BRZ	4.50"	12.75"	2.50"	5.20"	26
	CS/SS	5.50"	13.50"	2.50"	5.20"	35

■ Mark 60HP: Threaded & FSW Ends, Metric

Size	Material	A	B	C	D	Weight (kg)
DN15 & 20	DI/BRZ	92,0	311,2	44,5	130,0	6,8
	CS/SS	92,0	311,2	44,5	130,0	7,7
DN25	DI/BRZ	104,7	317,5	53,9	132,1	9,5
	CS/SS	106,2	323,9	53,9	132,1	11,3
DN32	DI/BRZ	104,7	317,5	53,9	132,1	9,5
DN40	DI/BRZ	114,3	323,9	58,7	132,1	10,4
	CS/SS	122,2	336,6	63,5	132,1	14,1
DN50	DI/BRZ	114,3	323,9	63,5	132,1	11,8
	CS/SS	139,7	342,9	63,5	132,1	15,9

■ Mark 60HP: Flanged End

Size	Flange	A1		B •	C	D	Weight (lbs)
		DI/BRZ	CS/SS	All	All	All	All
1/2"	150#	7.25"	7.25"	12.25"	1.69"	5.20"	21 •
	300#	7.50"	7.50"	12.25"	1.69"	5.20"	
	• 600#	8.00"	8.00"	12.25"	1.69"	5.20"	
3/4"	150#	7.25"	7.25"	12.25"	1.69"	5.20"	22 •
	300#	7.62"	7.62"	12.25"	1.69"	5.20"	
	• 600#	8.12"	8.12"	12.25"	1.69"	5.20"	
1"	150#	7.25"	7.25"	12.75"	2.62"	5.20"	37
	300#	7.75"	7.75"	12.75"	2.62"	5.20"	
	• 600#	8.25"	8.25"	12.75"	2.62"	5.20"	
1-1/4"	150#	7.87"	—	12.75"	2.62"	5.20"	37
	300#	8.37"	—	12.75"	2.62"	5.20"	
1-1/2"	150#	8.75"	8.75"	13.25"	2.31"	5.20"	45
	300#	9.25"	9.25"	13.25"	2.31"	5.20"	
	• 600#	9.87"	9.87"	13.25"	2.31"	5.20"	
2"	150#	10.00"	10.00"	13.50"	2.75"	5.20"	49
	300#	10.50"	10.50"	13.50"	2.75"	5.20"	
	• 600#	11.25"	11.25"	13.50"	2.75"	5.20"	

- 600# are not IFE
- For IFE, add 1" (25,4mm) to all "B" dimensions

■ Mark 60HP: Flanged End, Metric³

Size DN	Flange PN	A1		B ²	C	D	Weight (kg)
		DI/BRZ ¹	CS/SS	All	All	All	All
15	10/16	184,2	130,0	311,2	42,9	132,1	9,5
	25/40	184,2	130,0	311,2	42,9	132,1	
20	10/16	184,2	150,0	311,2	42,9	132,1	10,0
	25/40	184,2	150,0	311,2	42,9	132,1	
25	10/16	184,2	160,0	323,9	66,6	132,1	16,8
	25/40	184,2	160,0	323,9	66,6	132,1	
32	10/16	199,9	—	323,9	66,6	132,1	16,8
	25/40	199,9	—	323,9	66,6	132,1	
40	10/16	222,3	200,0	336,6	58,7	132,1	20,4
	25/40	222,3	200,0	336,6	58,7	132,1	
50	10/16	254,0	230,0	342,9	69,9	132,1	22,2
	25/40	254,0	230,0	342,9	69,9	132,1	

- 1 Not IFE and not per DIN3202
- 2 For IFE, Add 25,4mm
- 3 For DIN flanges above PN40, please consult factory

DIMENSIONS — MK61

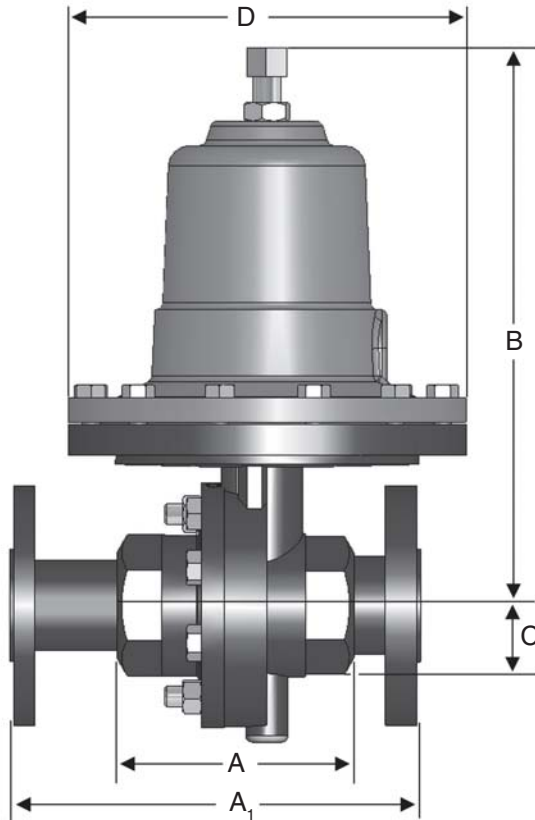

■ Mark 61: Threaded & FSW Ends

Size	Material	A	B	C	D	Weight (lbs)
1/2" & 3/4"	DI/BRZ	3.62	10.25	2.25	7.12	12
	CS/SS	3.62	10.25	2.25	7.12	13

■ Mark 61: Flanged Ends

Size	ANSI Flange	A1		B		C	D	Weight (lbs)	
		DI/BRZ	CS/SS	DI/BRZ	CS/SS	All	All	DI/BRZ	CS/SS
1/2 & 3/4"	150#	9.62	9.62	10.25	10.25	2.25	7.12	26	26
	300#	10.25	10.25	10.25	10.25	2.25	7.12	29	29

■ Mark 61: Threaded & FSW Ends, Metric

Size	Material	A	B	C	D	Weight (kg)
DN15 & 20	DI/BRZ	92,0	260,4	57,2	180,9	5,4
	CS/SS	92,0	260,4	57,2	180,9	5,9

■ Mark 61: Flanged Ends, Metric

Size DN	Flange PN	A1 ¹		B		C	D	Weight (kg)	
		DI/BRZ	CS/SS	DI/BRZ	CS/SS	All	All	DI/BRZ	CS/SS
15 & 20	10/16	244,4	244,4	260,4	260,4	57,2	180,9	11,8	11,8
	25/40	260,4	260,4	260,4	260,4	57,2	180,9	13,2	13,2

Note: 1/4" & 3/8" utilize 1/2" body with reducer bushings

¹ Not per DIN3202

The Jorlon Diaphragm - Revolutionary Diaphragm Sets New Standard

- Easily retrofitted - Jorlon can be easily retrofitted in the field with no additional parts. For regulators purchased after the fall of 1991, only the diaphragm needs to be changed to retrofit either SST or elastomer diaphragms.
- Chemical Compatibility — Jorlon is PTFE based, so it is compatible with most media except fluorinated gases and halogenated fluorocarbons. Whether the application is steam, process gases or fluids, Jorlon should be your first choice.
- High Pressure Limits — The MK60HP has been pressure tested well in excess of the maximum allowable pressures of the valve. For the smaller MK60s 2" (DN50) and below, it is fully rated to ANSI 300 Class pressure of 720 psi (50 bar) @ 100°F (38°C). While the material itself is vital in achieving these higher pressures, the design of the Sliding Gate regulator (MK60) is crucial in permitting this. The outstanding performance is a combination of the material itself and the unique design of the sliding gate regulator.
- Improved Droop Performance — A metal diaphragm is much more rigid than an elastomer diaphragm. As such, metal diaphragms have decreased sensitivity thereby diminishing performance and accuracy in a self operated regulator. Jorlon will improve droop performance when used instead of a SST diaphragm as its properties are more similar to those of elastomer materials.
- Less Expensive — Jorlon is less expensive than many other diaphragm materials, further increasing its customer value.
- High Steam Pressure Capability — Extensive steam testing of Jorlon in the Mark 60 pressure regulators qualifies this material for high pressure steam service. For Mark 60s sizes 2" (DN50) and below, you may install Jorlon in saturated steam service up to 405 psi (28 bar) @ 450°F (232°C). For steam service in larger Mark 60s, Jorlon qualifies up to 125 psi (8,6 bar) saturated steam.
- Fast Delivery — Rely on our 36 hour delivery with Jorlon as the diaphragm material.
- Extremely Long Life — Under 300 psi air, Jorlon surpasses 1,000,000 full stroke cycles without failure. The harshest test was on 450°F saturated steam, where Jorlon exceeded the cycle count for stainless steel by over 150 times - the test was stopped and the Jorlon diaphragm had yet to fail.
- Lower Cost of Ownership — Less droop provides more accuracy, improving efficiency and productivity. Extremely long life results in more production up-time, fewer spare parts expenses and less repair labor.

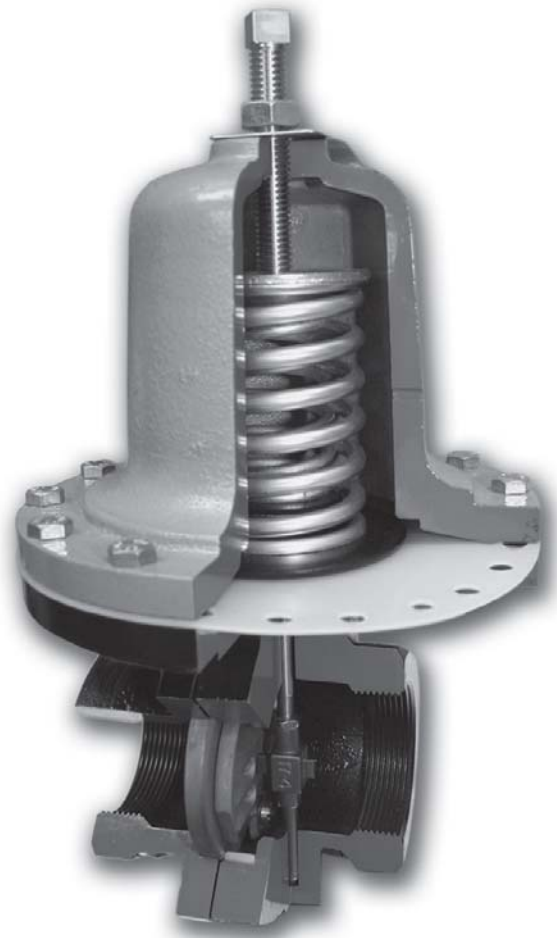

MK60 SELF-OPERATED PRESSURE REGULATORS

ORDERING SCHEMATIC

1	—	2	—	3	/	4	5	6	7	8	9	10

1	Model	
	60	Standard
	60HP	High Pressure
	60QC	Quick Change
	61	Large Diaphragm

2	Size	
	Inches	DN
	025	1/4"
	038	3/8"
	050	1/2"
	075	3/4"
	100	1"
	125	1-1/4"
	150	1-1/2"
	200	2"
	250	2-1/2" (MK60/60HP only)
	300	3" (MK60/60HP only)
	400	4" (MK60/60HP only)

MK61 available in 1/4" through 3/4" only

3	Body Material	
	DI	Ductile Iron
	BR	Bronze (1/4" - 2")
	CS	Carbon Steel
	S6	Stainless Steel
	CI	Cast Iron (2-1/2" - 4")

4	End Connections	
	1-4" - 2" MK60/61	
	PT	NPT
	BT	BSPT
	BP	BSPP
	SW	FSW
	I5	150# IFE
	F5	150# FE (Except IFE)
	I3	300# IFE
	F3	300# FE (Except IFE)
	2-1/2" - 4" MK60	
	I1	125# IFE
	I5	150# IFE
	I2	250# IFE
	I3	300# IFE
	I7	PN 10 DIN IFE (CS/S6) DN15-150
	I6	PN 16 DIN IFE (CS/S6) DN15-150
	I8	PN 25 DIN IFE (CS/S6) DN15-150
	I4	PN 40 DIN IFE (CS/S6) DN15-150

5	Trim	
	S3	303SS
	S6	316SS
	I3	303SSF/IFE (1" - 2")
	I6	316SSF/IFE (1" - 2")

6	Seat Material	
	A	303SST (1/4" - 2")
	B	316SST (1/4" - 2")
	V	303SS/Jorcote
	W	316SS/Jorcote
	X	303SS/JOR/JIC
	Y	316SS/JOR/JIC

7	Cv (Kv)			
	1	0.21 (0,28)	9	15 (12,93)
	2	0.42 (0,36)	A	25 (21,55)
	3	0.84 (0,72)	B	30 (25,86)
	4	1.6 (1,38)	D*	55 (47,41)
	5	2.5 (2,16)	F*	85 (73,28)
	6	4.4 (3,79)	G*	115 (99,14)
	7	6.4 (5,52)	I*	200 (172,41)
	8	9.5 (8,19)	* 2-1/2" - 4" only	

8	MK60 Spring Range PSI (BAR)					
	1/4" - 3/4"		1" - 2"		2-1/2" - 4"	
	16	2-23 (0,14-1,6)	05	1-5 (0,07-0,34)	29	7-18 (0,48-1)
	37	10-38 (0,69-3)	20	3-8 (0,21-5,5)	32	10-25 (0,69-2)
	56	20-55 (1-4)	28	5-20 (0,34-1)	42	15-35 (1-2)
	81	35-160 (2-11)	34	10-30 (0,69-2)		
	A6	95-220 (7-15)	53	20-45 (1-3)		
	D8	30-85 (2-6)	75	30-95 (2-7)		
			97	60-160 (4-11)		

8	MK60HP Spring Range PSI (BAR)			
	1/2" - 2"		2-1/2" - 4"	
	A1	75-190 (5-13)	71	30-75 (3-5)
	A7	100-320 (7-220)	98	65-110 (4-8)
	A9	150-450 (10-31)		

8	MK61 Spring Range PSI (BAR)			
	05	1-5 (0,07-0,34)	56	20-55 (1-4)
	10	2-12 (0,14-0,83)	63	20-80 (1-6)
	17	2-25 (0,14-2)	87	40-115 (3-8)
	36	10-35 (0,69-2)	70	25-160 (2-11)
			80	30-180 (2-12)

9	Diaphragm	
	S6	316 SST (1/4" - 2" only)
	VI	Viton
	BN	Buna-N (standard above 2"/DN50)
	JL	Jorlon

10	Actuator	
	MD	for Metal Diaphragm (1/4" - 2" only)
	ED	for Elastomer Diaphragm

Mark 601/602 Series

High Flow Pressure Regulators

The Mark 601 and 602 meet higher capacity requirements than standard regulators. The High Flow Mark 601 has Cv's as high as 50 (43Kv) and the Super High Flow Mark 602 has Cv's up to 70 (60,2 Kv). Each valve is standard with Jordan's Sliding Gate Seats, which helps to reduce the droop commonly associated with high flow regulators.

Jordan's unique self-operated sliding gate pressure regulator offers:

- Shorter stroke than a globe or plug-style valve
 - Faster response
 - Less offset
 - Smaller and lighter weight than globe-style valves
 - Longer diaphragm life
- Straight through -flow
 - Less turbulence, erosion and noise
 - Improved rangeability
 - Longer seat life
- Ease of maintenance
 - Interchangeable seats and Cv's
 - Fewer spare parts
 - Self-cleaning seats
 - No gaskets or o-rings



Diaphragm Materials

- Stainless Steel — standard
- Buna-N — optional
- Jorlon — optional
- Viton — optional

Service: Steam, water, oil, gas, air and chemicals

Shutoff: ANSI Class IV

Reduced Pressure Control Ranges: Select a range to match your setpoint. For optimal performance, your setpoint should fall in the upper portion of the selected range.

SPECIFICATIONS

Sizes: 1-1/2" & 2" (DN40 & DN50)

End Connections

- Threaded (NPT, BSPT, BSPP)
- ANSI Flanges (150#, 300#)
- DIN Flanges (PN10/16, PN25/40)

Body Materials

- Ductile Iron
- Bronze
- Carbon Steel (A216 WCB)
- Stainless Steel (A351/CF8M)

Trim Materials

- 303SST — Standard on Ductile Iron, Bronze, Carbon Steel valves
- 316SST — Standard on Stainless Steel Valves
- Monel, Hastelloy and other Alloys available

Seat Materials

- Jorcote on SST — Standard
- Jorcote/Jordanic on SST — For Severe Service

Model	Size (DN)	Spring Ranges	
		PSI	BAR
601 & 602	1-1/2" - 2" (DN40 - DN50)	20 - 45	1,72 - 3,10
		30 - 95	2,07 - 6,55
		60 - 160	4,14 - 11,03

Cv Values & Maximum Differential Pressures

- Mark 601

Cv (Kv)	Size (DN)	Seat Material	Maximum ΔP PSI (Bar)
25 (21,5)	1-1/2" & 2" (DN40 & DN50)	Jorcote	150 (10,34)
30 (25,8)	1-1/2" & 2" (DN40 & DN50)	Jorcote	150 (10,34)
35 (30,1)	1-1/2" & 2" (DN40 & DN50)	Jorcote	150 (10,34)
45 (38,7)	1-1/2" (DN40)	Jorcote	150 (10,34)
50 (43,0)	2" (DN50)	Jorcote	150 (10,34)

- Mark 602

Cv (Kv)	Size (DN)	Seat Material	Maximum ΔP PSI (bar)
65 (55,9)	1-1/2" (DN40)	Jorcote	150 (10,34)
70 (60,2)	2" (DN50)	Jorcote	150 (10,34)

DIMENSIONS — MK601/602

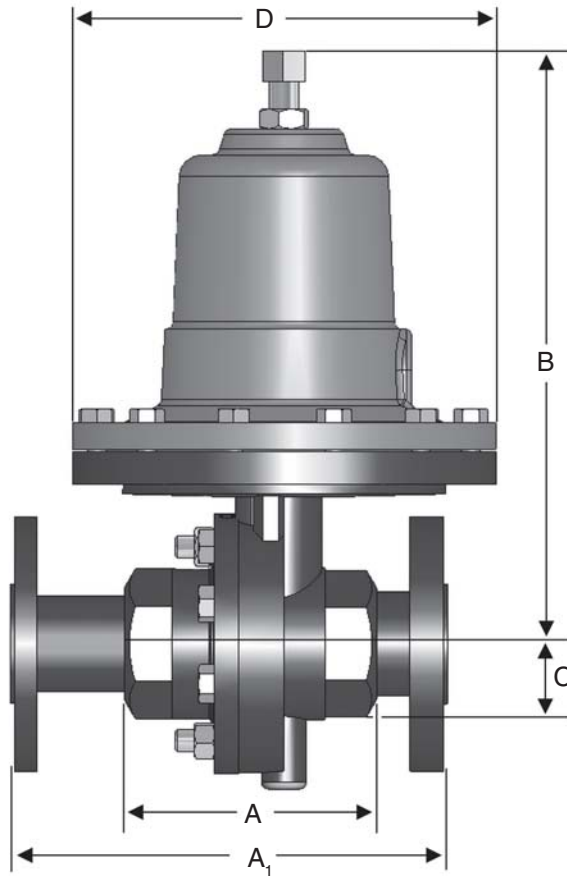

■ Mark 601/602: Threaded & FSW Ends

Size	Material	A	B	C	D	Weight (lbs)
1-1/2" - 2"	DI/BRZ	4.50	10.25	2.75	7.09	26
	CS/SS	5.50	11.00	2.75	7.09	35

■ Mark 601/602: Threaded & FSW Ends, Metric

Size	Material	A	B	C	D	Weight (kg)
DN40- DN50	DI/BRZ	114	260	70	180	11,8
	CS/SS	140	279	70	180	15,9

■ Mark 601/602: Flanged Ends

Size	ANSI Flange	A1		B		C	D	Weight (lbs)	
		DI/BRZ	CS/SS	DI/BRZ	CS/SS	All	All	DI/BRZ	CS/SS
1-1/2"	150#	10.00	10.00	10.25	11.22	2.31	7.09	42	46
	300#	10.25	10.25	10.25	11.22	2.31	7.09	45	52
2"	150#	10.00	10.00	10.25	11.42	2.75	7.09	46	50
	300#	10.50	10.50	10.25	11.42	2.75	7.09	49	55

Not IFE

Not ANSI Standard

■ Mark 601/602: Flanged Ends, Metric

Size	Flange PN	A1		B		C	D	Weight (kg)	
		DI/BRZ	CS/SS	DI/BRZ	CS/SS	All	All	DI/BRZ	CS/SS
DN40	10/16	254	254	279	285	58,7	180	19,1	20,9
	25/40	260	260	279	285	58,7	180	20,4	23,6
DN50	10/16	254	230	279	290	69,9	180	20,9	22,7
	25/40	267	230	279	290	69,9	180	22,2	24,9

Not IFE

Not per DIN3202

ORDERING SCHEMATIC

1	—	2	—	3	/	4	5	6	7	8	9	10	11	12
----------	---	----------	---	----------	---	----------	----------	----------	----------	----------	----------	-----------	-----------	-----------

1	Model	
601	High Flow	
602	Super High Flow	

6	Seat Material	
V	303SS/Jorcote	
W	316SS/Jorcote	
X	303SS/JOR/JIC	
Y	316SS/JOR/JIC	

2	Size		
		Inches	DN
150	1-1/2"	DN40	
200	2"	DN50	

7	CV (Kv)	
A	25 (22)	
B	30 (26)	
V	35 (30)	
W	45 (39)	
C	50 (43)	
Y	65 (56)	
E	70 (60)	

3	Body Material	
DI	Ductile Iron	
BR	Bronze	
CS	Carbon Steel	
S6	Stainless Steel	

8	Range	
53	20-45 (1,38-3,01)	
75	30-95 (2,07-6,55)	
97	60-160 (4,14-11,03)	

4	End Connections	
PT	NPT	
BT	BSPT	
I5	150# IFE CS or SST*	
F5	150# FE DI or BR	
I7	PN10 IFE, CS or SST*	
F7	PN10 FE DI or BR	
I6	PN16 IFE, CS or SST*	
F6	PN16 FE DI or BR	
BP	BSPP	
SW	FSW	
I3	300# IFE, CS or SST*	
F3	300# FE DI or BR	
I8	PN25 IFE, CS or SST*	
F8	PN25 FE DI or BR	
I4	PN40 IFE, CS or SST*	
F4	PN40 FE DI or BR	

9	Diaphragm	
S6	316 SST	
VI	Viton	
BN	Buna-N	
JL	Jorlon	

10	Actuator	
MD	for Metal Diaphragm	
ED	for Elastomer Diaphragm	

* IFE for 2" only

5	Trim	
S3	303SS	
S6	316SS	
I3	303SSF/IFE	
I6	316SSF/IFE	

11	Double Bolting	
P1	None	
ZZ	Non-Standard	

12	Accessories	
0	None	
6	316 SS Bolting	
7	Hi-temperature bolting	
Z	Non-standard	

Jordan Valve offers a full range of pressure regulators in addition to the Mark 60 Self-Operated Pressure Regulator.

Mark 62 Internally Piloted Pressure Regulators

The Mark 62 is a specialty valve designed for critical application regulation in locations where space is limited. Small and lightweight in design, the Mark 62 valve provides the accuracy of a piloted valve with the size, weight and appearance of a single, self-operated valve.



Mark 63/64 Differential Pressure Regulators

The Mark 63 is designed to maintain a constant differential between the pressure on the discharge side of the regulator and the signal pressure loaded on the diaphragm. The Mark 64 provides the same flow capacity as the Mark 63 but with less offset in controlled pressure due to a larger diaphragm.



Mark 65 Vacuum Regulators

The Mark 65 vacuum regulators control very accurately and shutoff tightly to maintain the proper vacuum setting. They are used to maintain vacuums at predetermined settings and to regulate vacuums on evaporators, cookers, grinding fixtures, milking machines, altitude chambers and other vacuum systems.



Mark 66 Air-Loaded Pressure Regulators

The Mark 66 is a highly accurate and economical air loaded pressure regulator that provides regulation from a local station or from a remote station. The operation of the MK66 requires no control spring or pilot. Instead, a static air signal is applied to the top of the diaphragm to determine the setpoint.



Mark 67 Pilot-Operated Pressure Regulators

The Mark 67 is for critical pressure reducing applications and provides greater accuracy and lower offset than can be achieved with a self-operated regulator. Because of its versatility in control, and its accuracy, the Mark 67 can be used in a wide variety of applications including: controlling the pressure of gaseous oxygen to furnaces at steel mills, controlling pressure of sealing oil on turbines, and pressure control on steam mains and distribution lines.



Mark 68G Pressure Regulator

The Mark 68G is a globe-style pressure reducing regulating valve that offers high capacity, accurate regulation, and easy servicing, making it the ideal choice for your industrial-grade pressure reducing applications.



Mark 68HP High Pressure Regulating Valve

The Mark 68HP is designed primarily for high pressure steam service as commonly found in power plants, refineries, pulp & paper mills, and other high pressure process applications.

