

Mark 67 Series

Pilot-Operated Pressure Regulators

The MK67 Series is for critical pressure reducing applications and provides greater accuracy and lower offset than can be achieved with a self-operated regulator.

The MK67 regulator combines the short stroke of the sliding gate with the action of a pilot valve to create a faster, more accurate (meaning less droop as your flows increase) response. This allows for higher accuracy in a self-contained valve where control systems are not an option.

However, the primary benefit of the sliding gate seat is low total cost of ownership. This design provides unsurpassed seat and diaphragm life, ease of installation, simplified maintenance and more accurate performance.

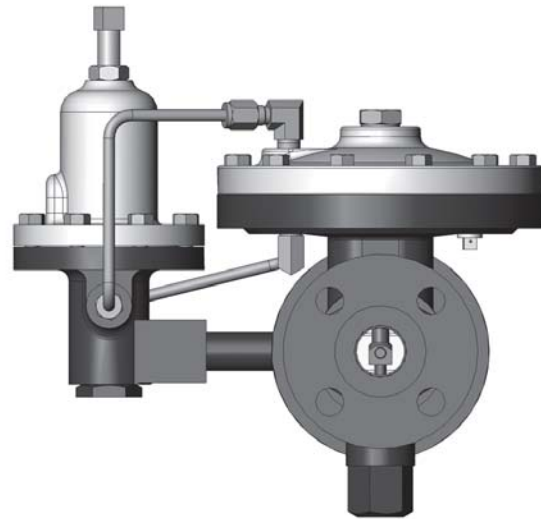

OPERATION

The Mark 67 is normally closed. The upstream pressure enters the body and passes through the piping to the pilot valve. The pilot valve is normally open, allowing the upstream pressure to act on the top of the main valve diaphragm. This force pushes the stem downward, opening the main valve. As the downstream pressure rises to the setpoint, the pilot senses the rising pressure and begins to close, which throttles the flow to the main diaphragm. The pressure on the main valve diaphragm is bled off downstream, and the main valve closes. In this way, the Mark 67 modulates between open and closed to maintain control.

Because of its versatility and accuracy, the Mark 67 can be used in a wide variety of applications including: controlling the pressure of gaseous oxygen to furnaces at steel mills, controlling pressure of sealing oil on turbines, and pressure control on steam mains and distribution lines.

FEATURES

- Mark 67 — features the Mark 69 plug-style pilot valve for pressure settings ranging from 10 psi to 200 psi (0,69 bar to 13,79 bar)
- Mark 67 with 69D Pilot — features the optional differential pilot for services where a constant differential must be maintained between two fluids. It is commonly used for atomizing steam and oil for combustion on oil burners where a constant differential between the steam and oil must be maintained.
- Mark 67 with 69A Pilot — features the optional air-loaded pilot that allows remote adjustment of your pressure setpoint by changing the air pressure loaded to the dome. This option is recommended where droop must be kept to a minimum, where remote control is needed, or where frequent setpoint changes may be required.
- Sliding Gate Seats — main valve features unique seats for straight-through flow with reduced turbulence and quiet operation, fast response and tight shutoff.



Jordan Valve

Jordan Valve, a Division of Richards Industries

3170 Wasson Road • Cincinnati, Ohio 45209

Telephone 513-533-5600 • Fax 513-871-0105

Toll-Free Telephone: 800-543-7311 (U. S. A. & Canada)

E-Mail: info@richardsind.com • URL: www.jordanvalve.com

SPECIFICATIONS

Line Sizes: 1/2" (DN15) through 6" (DN150)

End Connections

- Threaded — FNPT, BSPT, BSPP
- ANSI Flanges — 150#, 300#
- DIN Flanges — PN10/16, PN25/40

Body Materials

- Ductile Iron
- Cast Iron
- Carbon Steel — A216 WCB
- Stainless Steel — A351 CF8M

Trim Materials

- 303 SS — Standard on DI, CI or CS valves
- 316SS — Standard on SS valves

Seat Materials

- Jorcote on SST — Standard
- Jorcote/Jordanic — For severe service

Diaphragm Material:

- Stainless Steel

Service: steam, water, oil, gas, air and chemicals

Shutoff: ANSI Class IV

Gas Specifications: meets the requirements of General Services Administration Standard Heating Specification PB54-1530 (AM.1), Paragraph 27.4

Reduced Pressure Setpoint Ranges, PSI (BAR)

Model	6769L		6769H & 6769D			
Range	10-15 (0,7-1,0)	13-25 (0,9-1,7)	10-30 (0,7-2,1)	25-75 (1,7-5,2)	70-150 (4,8-10,3)	120-200 (10,3-13,8)

Operating Pressure Drops (Specify when ordering)

Size	Differential Pressure Range PSI (BAR)			
1/2" - 4" (DN15-100)	15-25 (1,0-1,7)	25-150 (1,7-10,3)		
6" (DN150)	15-25 (1,0-1,7)	25-50 (1,7-3,4)	50-100 (3,4-6,9)	100-150 (6,9-10,3)

Notes

- There is an overlap in set pressure ranges for 69L and 69H pilots. The 69H is recommended for differential pressures greater than 30 psi (2,07 bar).
- For 6" (DN150) size, four differential pressure ranges are specified. It is necessary to know which differential range applies in order to size the valve accurately.
- For service below or above the recommended differential pressure ranges, consult factory. For service below or above stated set pressure, consult factory.

CV/Kv Values

Valve Size (DN)	Max. Cv (Kv)	Valve Size (DN)	Max. Cv (Kv)
1/2" (DN15)	5,0 (4,3)	2" (DN50)	50 (43,0)
3/4" (DN20)	9.5 (8,2)	2-1/2" (DN65)	55 (47,3)
1" (DN25)	15 (12,9)	3" 9DN80)	115 (98,9)
1-1/4" (DN32)	25 (21,5)	4" (DN100)	200 (172,0)
1-1/2" (DN40)	30 (25,8)	6" (DN150)	395 (339,7)

Body Pressure/Temperature Ratings

Size (DN)	Body Material	End Connection	Pressure Rating* psi @ 100°F (bar @ 37,8°C)		Pressure Rating* psi/max temp. °F (bar/max temp. °C)	
			Std. Main Valve Bolting	Double Bolted Main Valve	Std. Main Valve Bolting	Double Bolted Main Valve
1/2" to 2" (DN15 to 50)	DI	150FE	250 (17)	250 (17)	200/400 (14/204)	200/400 (14/204)
		300FE	500 (35)	500 (35)	500/400 (35/204)	500/400 (35/204)
		TE	500 (35)	600 (41)	500/400 (35/204)	600/400 (41/204)
	CI	125FE	200 (14)	200 (14)	140/400 (10/204)	140/400 (10/204)
		250FE	500 (35)	500 (35)	290/400 (20/204)	290/400 (20/204)
		TE	500 (35)	500 (35)	290/400 (20/204)	290/400 (20/204)
	CS	150FE	285 (20)	285 (20)	125/650 (9/343)	125/650 (9/343)
		300FE	500 (35)	600 (41)	500/650 (35/343)	535/650 (37/343)
		TE	500 (35)	600 (41)	500/650 (35/343)	600/650 (41/343)
	SS	150FE	275 (19)	275 (19)	125/650 (9/343)	125/650 (9/343)
		300FE	500 (35)	600 (41)	445/650 (31/343)	445/650 (31/343)
		TE	500 (35)	600 (41)	500/650 (35/343)	600/650 (41/343)
2-1/2" to 6" (DN65 to 150)	DI	150FE	250 (17)	250 (17)	200/400 (14/204)	200/400 (14/204)
		300FE	500 (35)	500 (35)	500/400 (35/204)	500/400 (35/204)
	CI	125FE	200 (14)	200 (14)	140/400 (10/204)	140/400 (10/204)
		250FE	500 (35)	500 (35)	290/400 (20/204)	290/400 (20/204)
	CS	150FE	285 (20)	285 (20)	125/650 (9/343)	125/650 (9/343)
		300FE	500 (35)	600 (41)	500/650 (35/343)	535/650 (37/343)
	SS	150FE	275 (19)	275 (19)	125/650 (9/343)	125/650 (9/343)
		300FE	500 (35)	600 (41)	445/650 (31/343)	445/650 (31/343)

*these ratings are for High Pressure Pilot, consult factory for Low Pressure Pilot (which might be lower)

MK67 PILOT-OPERATED PRESSURE REGULATORS

DIMENSIONS

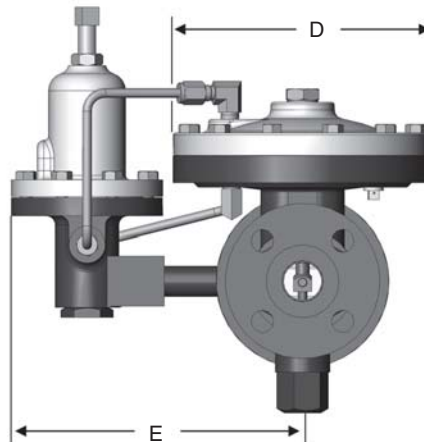
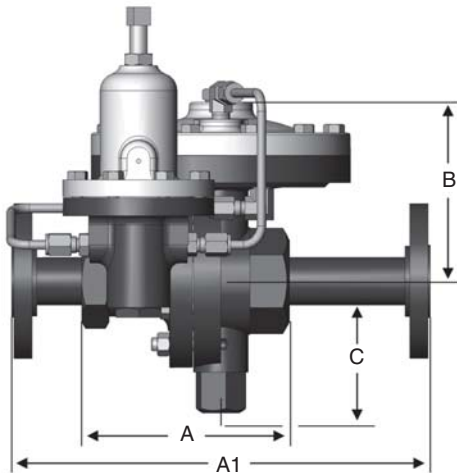

■ Threaded Ends: MK6769H/L

Size	Dimensions (Inches)							Weight (lbs.)
	A		B	C	D	E (H)	E (L)	
	DI	CS/SS	ALL	ALL	ALL	ALL	ALL	
1/2"	5.31	5.50	5.06	3.50	7.12	8.00	11.50	32
3/4"	5.31	5.50	5.06	3.50	7.12	8.00	11.50	32
1"	5.69	6.50	5.25	3.62	7.12	8.00	11.50	36
1-1/4"	5.88	6.50	5.43	3.75	7.12	8.00	11.50	36
1-1/2"	8.18	8.18	7.00	5.00	10.62	9.5	13.00	37
2"	8.18	8.18	7.00	5.00	10.62	9.5	13.00	39

■ Threaded Ends: MK6769H/L, DIN

Size (DN)	Dimensions (mm)							Weight (kg)
	A		B	C	D	E (H)	E (L)	
	DI	CS/SS	ALL	ALL	ALL	ALL	ALL	
15	135	140	129	89	181	203	292	14,5
20	135	140	129	89	181	203	292	14,5
25	145	165	133	92	181	203	292	16,3
32	149	165	138	95	181	203	292	16,3
40	208	208	178	127	270	241	330	16,8
50	208	208	178	127	270	241	330	17,7

■ Flanged Ends: MK6769H/L

Size	Flange	Dimensions (Inches)						Weight (lbs.)
		A1	B	C	D	E (H)	E (L)	
1/2"	150#	11.50	5.06	3.50	7.12	8.0	11.5	36
	300#	11.50	5.06	3.50	7.12	8.0	11.5	36
3/4"	150#	11.50	5.06	3.50	7.12	8.0	11.5	38
	300#	11.50	5.06	3.50	7.12	8.0	11.5	38
1"	150#	11.50	5.25	3.62	7.12	8.0	11.5	42
	300#	11.50	5.25	3.62	7.12	8.0	11.5	42
1-1/4"	150#	11.50	5.43	3.75	7.12	8.0	11.5	44
	300#	11.50	5.43	3.75	7.12	8.0	11.5	44
1-1/2"	150#	14.50	7.00	5.00	10.62	9.5	13.0	49
	300#	14.50	7.00	5.00	10.62	9.5	13.0	49
2"	150#	14.50	7.00	5.00	10.62	9.5	13.0	53
	300#	14.50	7.00	5.00	10.62	9.5	13.0	53

■ Flanged Ends: MK6769H/L, DIN

Size (DN)	Flange (PN)	Dimensions (mm)						Weight (kg)
		A1	B	C	D	E (H)	E (L)	
15	10/16	292	129	89	181	203	292	16,3
	25/40	292	129	89	181	203	292	16,3
20	10/16	292	129	89	181	203	292	17,2
	25/40	292	129	89	181	203	292	17,2
25	10/16	292	133	92	181	203	292	19,0
	25/40	292	133	92	181	203	292	19,0
32	10/16	292	138	95	181	203	292	20,0
	25/40	292	138	95	181	203	292	20,0
40	10/16	368	178	127	270	241	330	22,2
	25/40	368	178	127	270	241	330	22,2
50	10/16	368	178	127	270	241	330	24,0
	25/40	368	178	127	270	241	330	24,0

Larger sizes

Size	ANSI Flange	Dimensions (Inches)						Weight (lbs.)
		A	B	C	D	E (H)	E (L)	
2-1/2"	125-150#	10.87	10.68	6.93	12.75	10.00	13.50	173
	250-300#	11.50	10.68	6.93	12.75	10.00	13.50	173
3"	125-150#	11.75	10.68	6.93	12.75	10.00	13.50	193
	250-300#	12.50	10.68	6.93	12.75	10.00	13.50	193
4"	125-150#	13.87	11.88	8.00	12.75	11.00	12.00	223
	250-300#	14.50	11.88	8.00	12.75	11.00	12.00	223
6"	125-150#	17.75	12.57	9.00	12.75	11.00	13.00	313
	250-300#	18.62	12.57	9.00	12.75	11.00	13.00	313

Larger sizes

Size (DN)	Flange (PN)	Dimensions (mm)						Weight (kg)
		A	B	C	D	E (H)	E (L)	
65	10/16	283	271	176	324	254	343	78,5
	25/40	283	271	176	324	254	343	78,5
80	10/16	312	271	176	324	254	343	87,5
	25/40	312	271	176	324	254	343	87,5
100	10/16	350	302	203	324	279	305	101,2
	25/40	350	302	203	324	279	305	101,2
150	10/16	471	319	229	324	279	330	142,0
	25/40	471	319	229	324	279	330	142,0

ORDER SCHEMATIC

To specify a MK67 Pilot-Operated Pressure Regulator, build a model number by making a selection from each category in the Product Designator Coding System below.

1	—	2	—	3	/	4	5	6	7	8	9	10	11

1	Model	
	6769H	Standard
	6769L	Low ΔP Version
	6769D	Differential Pressure Pilot
	6769A	Air Loaded Pilot

2	Size		
		Inches	DN
	050	1/2"	DN15
	075	3/4"	DN20
	100	1"	DN25
	125	1-1/4"	DN32
	150	1-1/2"	DN40
	200	2"	DN50
	250	2-1/2"	DN65
	300	3"	DN80
	400	4"	DN100
	600	6"	DN150

3	Body Material	
	DI	Ductile Iron
	CS	Carbon Steel (WCB)
	CI	Cast Iron
	S6	Stainless Steel

4	End Connections	
	PT	NPT
	BT	BSPT
	BP	BSPP
	SW	FSW
	I5	150#IFE CS or SST valves or DI above 2"
	I3	300#IFE CS or SST valves or DI above 2"
	I1	125#IFE CI above 2"
	I2	250#IFE CI above 2"
	I7	IFE PN10, CS or SST
	I6	IFE PN16, CS or SST
	I8	IFE PN25, CS or SST
	I4	IFE PN40, CS or SST

5	Trim	
	M	303SS
	S	316SS
	B	303/BRS

6	Pressure Drop		
	1	15-25 (1,0-1,7)	ALL
	2	25-150 (1,7-10,3)	1/2"-4" (DN15-100)
	3	25-50 (1,7-3,4)	6" (DN150)
	4	50-100 (3,4-6,9)	6" (DN150)
	5	100-150 (6,9-10,3)	6" (DN150)

7	Seat Material	
	V	303SS/JORCOTE
	W	316SS/JORCOTE

8		Cv	Kv
	5	2.5	2,2
	6	4.4	3,78
	K	5.0	4,3
	7	6.4	5,5
	8	9.5	8,2
	9	15	12,9
	A	25	21,5
	B	30	25,8
	V	35	30,1
	C	50	43,0
	D	55	47,3
	G	115	98,9
	I	200	172,0
	J	395	339,7

9	Range	
	B4	10 - 15 (0,7 - 1,0) MK6769L only
	B6	13 - 25 (0,9 - 1,7) MK6769L only
	40	10 - 30 (0,7 - 2,1)
	65	25 - 75 (1,7 - 5,2)
	99	70 - 150 (4,8 - 10,3)
	A8	120 - 200 (8,3 - 13,8)

10	Diaphragm/Actuator	
	S6MD	316SST

11	Pilot	
	SB	303/BRS Trim
	S3	303/SST Trim
	S6	316/SST Trim