

3PC STAINLESS STEEL 316 BALL VALVE

V-3NM 1000WOG



1/2"-3" FULL PORT



4" FULL PORT

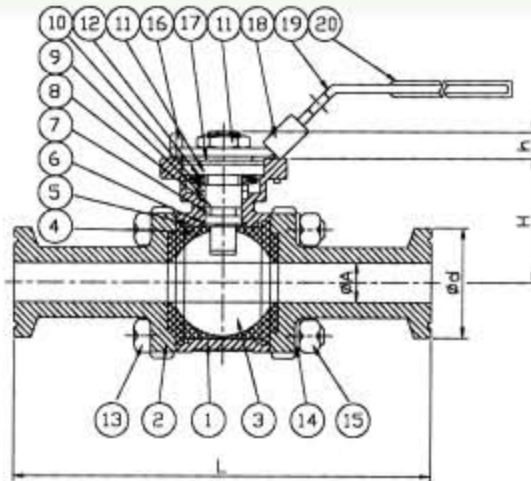

NO	PARTS	MATERIAL
1	BODY	A351-CF8M
2	CAP	AISI 316/316L
3	BALL	A351-CF8M
4	STEM	PTFE
5	GASKET	PTFE
6	THRUST WASHER	PTFE
7	O-RING	VITON
8	SETM PACKING	PTFE
9	PACKING	PTFE
10	RING	S.S.304
11	HANDLE NUT	S.S.304
12	BELLEVILLE WASHER	S.S.410
13	BOLTS	AISI 304
14	BOLT WASHER	AISI 304
15	BOLT NUT	AISI 304
16	SET SCREW	S.S.304
17	SETM WASHER	S.S.304
18	LOCKING PLATE	S.S.304
19	HANDLE	S.S.304
20	HANDLE SLEEVE	VINYL GRIP

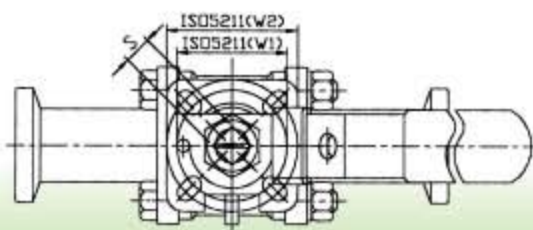

SIZE	ød	L	H	h	øA	S	W1	W2	ISO-5211
1 / 2"	25	116	38	7	9.5	9	36	42	F03/F04
3 / 4"	25	119	42.4	9	15.9	9	36	42	F03/F04
1"	50.4	124	48.5	12	22.2	11	42	50	F04/F05
1 1/2"	50.4	141	66	16	35	14	50	70	F05/F07
2"	63.9	162	74	16	47.6	14	50	70	F05/F07
2 1/2"	77.4	197	100.5	19	60.3	17	70	102	F07/F10
3"	90.9	229	109.8	19	73	17	70	102	F07/F10
4"	118.9	243	141	24	97.4	17	70	102	F07/F10

V-3N 1000WOG



1/2"-3" FULL PORT



4" FULL PORT

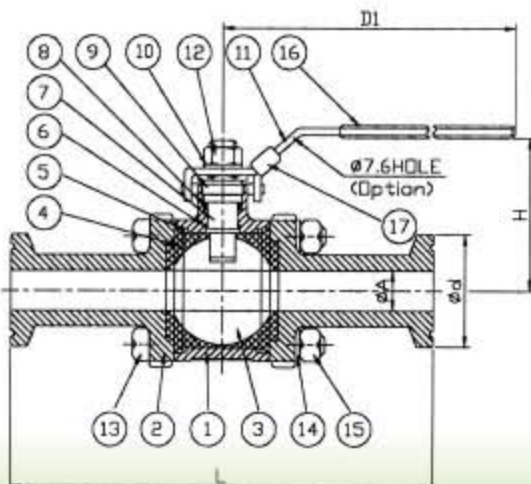
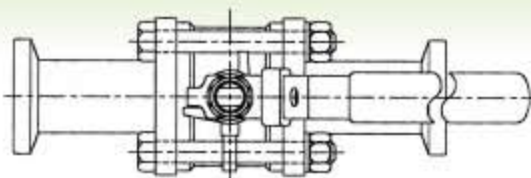

NO	PARTS	MATERIAL
1	BODY	A351-CF8M
2	CAP	AISI 316/316L
3	BALL	A351-CF8M
4	STEM	PTFE
5	GASKET	PTFE
6	THRUST WASHER	PTFE
7	SETM	ASTM A276 Gr.316
8	PACKING	PTFE
9	GLAND	S.S.304
10	BEVEL WASHER	AISI 301
11	HANDLE	S.S.304
12	SPRING WASHER	S.S.304
13	BOLTS	AISI 304
14	BOLT WASHER	AISI 304
15	BOLT NUT	AISI 304
16	HANDLE SLEEVE	VINYL GRIP
17	LOCKING PLATE	S.S.304

SIZE	D1	H	L	øA	ød
1 / 2"	105	59.10	116	9.5	25
3 / 4"	105	62.55	119	15.9	25
1"	128	70.70	124	22.2	50.4
1 1/2"	154	89.10	141	35	50.4
2"	194	98.15	162	47.6	63.9
2 1/2"	194	110.6	197	60.3	77.4
3"	276	124.0	229	73	90.9
4"	335	168.5	243	97.4	118.9