

REFER DIMENSIONS	TOLERANCE
0~400	± 2
400~800	± 3
800 ↑	± 4

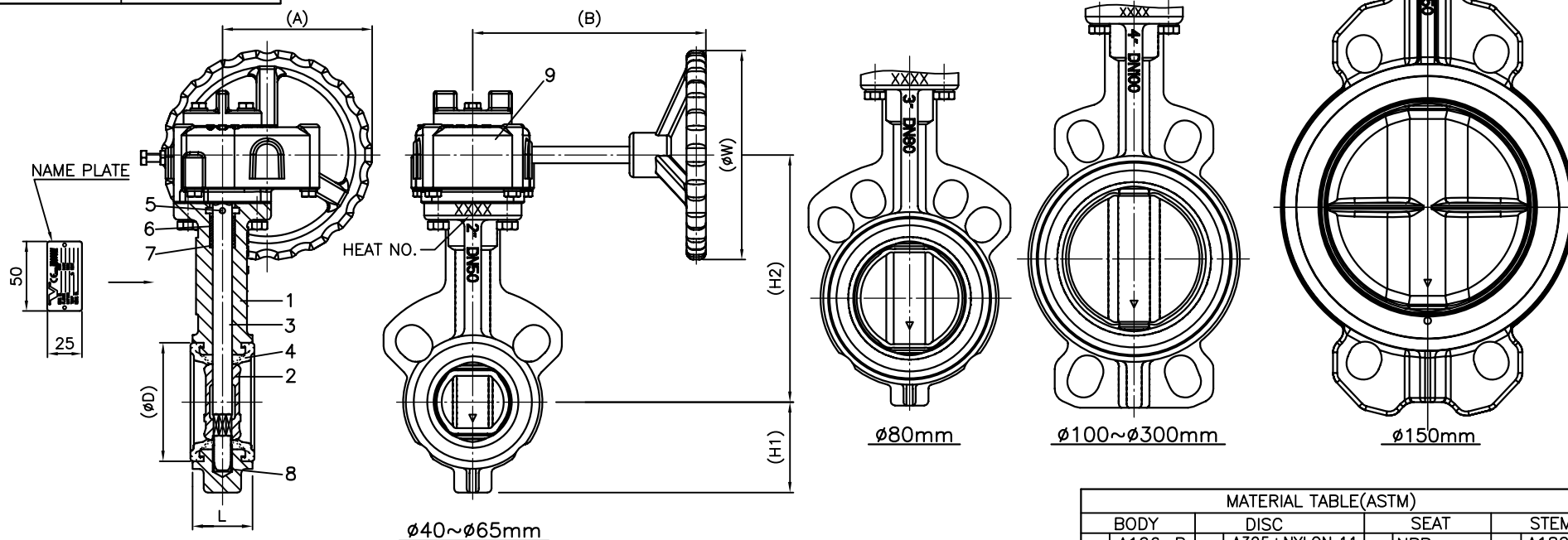

MATERIAL TABLE (ASTM)			
BODY	DISC	SEAT	STEM
A126-B	A395+NYLON 11	NBR	A182 F6A
A395	A351 CF8	EPDM	A182 F304
	A351 CF8M	CR	A182 F316
	B148 C95400		

SIZE	L	φD	H1	H2	WEIGHT	GEAR	A	B	φW
40	33	70.5	60	157	5.3 KG	C07	116	162	150
50	43	85	65	180	6.3 KG				
65	46	97	71	192	7.1 KG				
80	46	115	77	199	7.3 KG				
100	52	138	107	218	8.6 KG				
125	56	166	122	234	10.6 KG				
150	56	192	150	247	11.5 KG	C10	163	205	200
200	60	242	165	281	21 KG				
250	68	303	201	327	28.7 KG				
300	78	355	234	350	40 KG				

FLANGE DIMENSION ACCORDING TO

JIS 16K(*)	MAX WORKING PRESS :16 kg/cm <sup>2</sup>
JIS 20K(*)	SHELL TEST :24 kg/cm <sup>2</sup>
PN 16(*)	SEAT TEST :18 kg/cm <sup>2</sup>
PN 10	TEST FLUID :WATER
JIS 10K	MAX WORKING PRESS :10 kg/cm <sup>2</sup>
ANSI B16.5 150LB	SHELL TEST :15 kg/cm <sup>2</sup>
BS 10 Table E	SEAT TEST :11 kg/cm <sup>2</sup>
	TEST FLUID :WATER

(\*):8",10",12" CAN'T SUITABLE FOR A126-B BODY.

9	GEAR BOX	1	ASTM A126-B
8	BUSH	1	ASTM B62
7	O-RING	2	NBR
6	BUSH	1	DELTRIN
5	PIN	1	ASTM A182 F304
4	SEAT	1	SEE MATERIAL TABLE
3	STEM	1	
2	DISC	1	
1	BODY	1	
ITEM NO.	PART NAME	Q'TY	MATERIAL



**VALUE VALVES CO., LTD.**  
 NO.9,CHUNG SHAN RD.,  
 TU-CHENG INDUSTRIAL DISTRICT,  
 TAIPEI HSIEN,TAIWAN 236  
 TEL:+886-2-22698000  
 FAX:+886-2-22686600  
 www.valuevalves.com

DESN BY	CHK BY	AUTH BY	ISSUE DATE	MATERIAL
POCKY		GRANT	2009.03.25	
2009.03.25		2009.03.25		
			SCALE	1/3.5
			UNIT	mm

VF-730 BUTTERFLY VALVE			
φ40mm(1.5")~φ300mm(12") GEAR OPERATED			
SIZE A4	DRAWING NO	S730000FG01	REV 1