

MATERIAL TABLE(ASTM)			
BODY	DISC	SEAT	STEM
A126-B	A536-65-45-12	NBR	A182-F6A
A536-65-45-12	A351-CF8	EPDM	A182-F304
	A351-CF8M	CR	A182-F316
	B148-954		

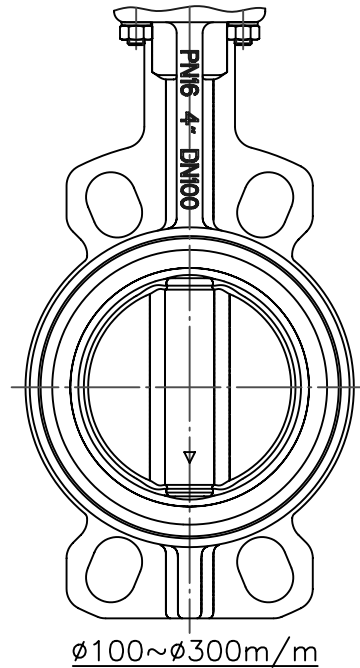
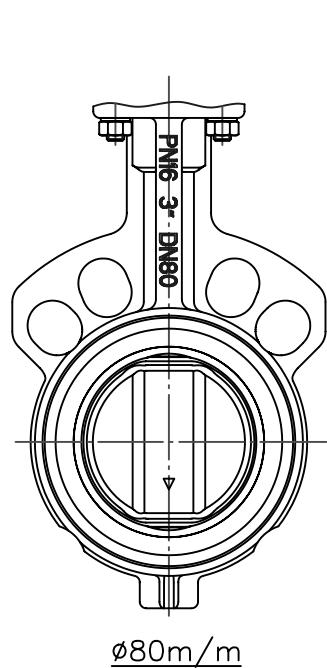
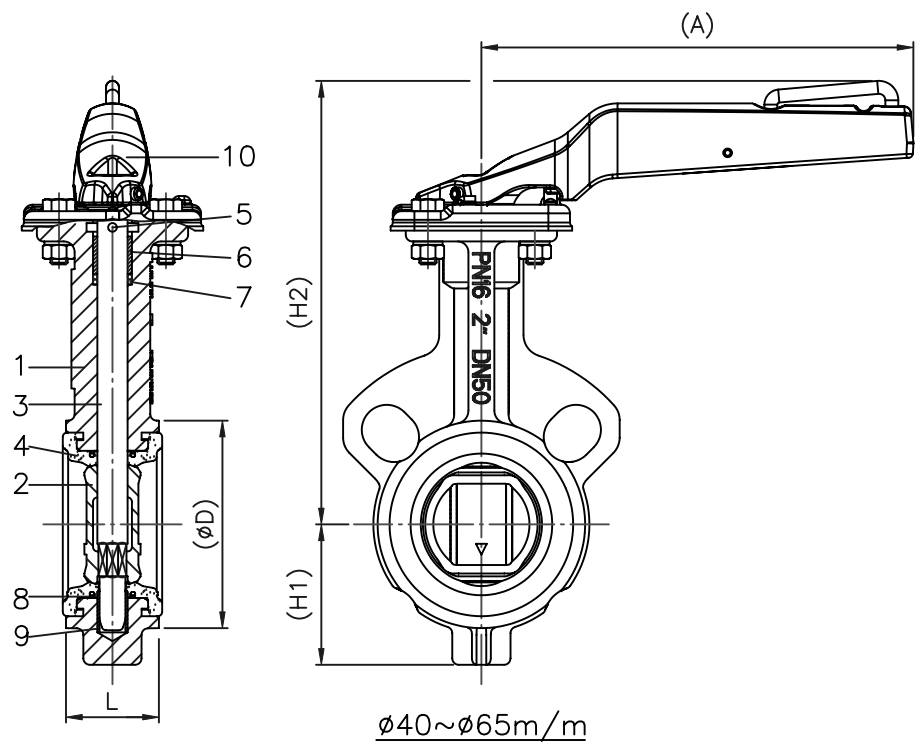

SIZE	L	ØD	H1	H2	LEVER	A
40 mm	33	81	60	181	L7A	200
50 mm	43	96	65	204		
65 mm	46	110	71	216		
80 mm	46	124	77	223		
100 mm	52	148	107	242		
125 mm	56	180	122	258	L7B	250
150 mm	56	206	140	271		
200 mm	60	259	165	308		
250 mm	68	320	201	354	L10	355
300 mm	78	370	234	377		

MAX WORKING PRESS	bar
SHELL TEST	bar
SEAT TEST	bar
TEST FLUID	Water

FLANGE DIMENSION ACCORDING TO	
	PN 16
	PN 10
	JIS B 2213 10K
	ANSI B16.5 150LB
	BS 10 Table E

ITEM No.	PART NAME	Q'TY	MATERIAL
10	LEVER	1	ASTM A536-65-45-12
9	BOTTOM BUSHING	1	ASTM B62
8	BACK-UP RING	2	PLASTIC
7	O-RING	2	NBR
6	UPPER BUSHING	1	DELTRIN
5	STOP PIN	1	ASTM A182 F316
4	SEAT	1	SEE MATERIAL TABLE
3	STEM	1	
2	DISC	1	
1	BODY	1	

**捷流閥業股份有限公司**  
 VALUE VALVE CO.,LTD.  
 台北縣土城工業區中山路9號  
 TEL:(02)22685881  
 FAX:(02)22681434

DESN BY	CHK BY	AUTH BY	ISSUE DATE	92/4/22
			MATERIAL	
			SCALE	
			UNIT	mm

VF-730 BUTTERFLY VALVE	
Ø40mm~300mm LEVER OPERATED	
SIZE A4	DRAWING NO T730000L02
	REV 1