

## INSTALLATION, OPERATION AND MAINTENANCE MANUAL

### Floating Valve with Buoy



Ref. GENEBRE : 2852 – 2856 – 2856N – 3886 – 3887

## **Installation, Operation and Maintenance Instructions**

<b>1. Product description</b>	<b>3</b>
<b>2. Exploded view</b>	<b>3</b>
<b>3. Storage</b>	<b>5</b>
<b>4. Installation Instructions</b>	<b>5</b>
4.1 Preparation	5
4.2 Assembly	6
<b>5. Operating Instructions</b>	<b>7</b>
5.1 Use	7
5.2 Operation	7
<b>6. Maintenance Instructions</b>	<b>7</b>
<b>7. Repair Instructions</b>	<b>8</b>
7.1 Disassembly	8
7.2 Reassembly	9
<b>8. Health and Safety</b>	<b>9</b>

## 1) Product description

**Genebre, S.A.** offers a wide range of valves designed and assembled to handle and drive fluids in industrial procedures.

The compatibility of materials used to build the valves (see technical specifications) and the application of valves to the different industrial processes is at user's risk. Valves will have an optimal behaviour when working conditions do not exceed pressure and temperature limits for which they have been designed. Please, refer to the product datasheet.

Art. 2852: Buoy AISI 316 for floating valve art. 2856/2856N

Art. 2856: Floating valve AISI 316 with ISO 228 thread / EN 1092 flange

Art. 2856N: Floating valve AISI 316 with NPT thread

Art. 3886: Floating valve AISI 304 with ISO 228 thread

Art. 3887: Buoy AISI 304 for floating valve art. 3886

## 2) Exploded view

Art. 2856/2856N/3886 ( $\leq 2\frac{1}{2}$ "):

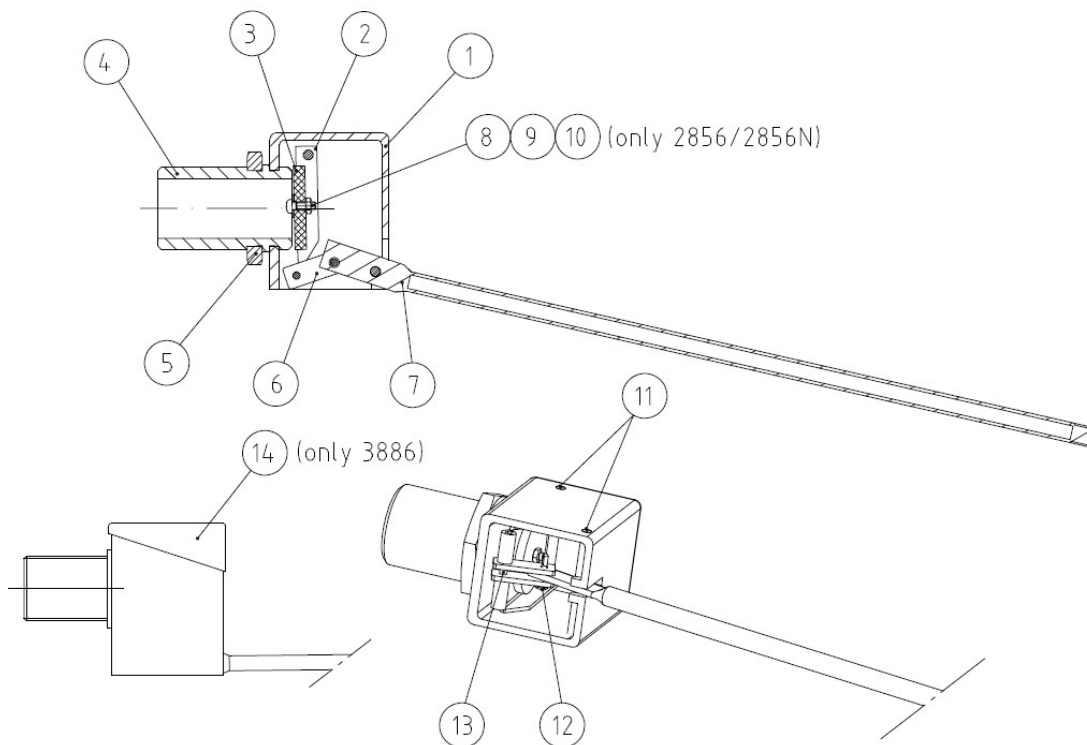

-Fig. 1-

14	TAPA/COVER	—	PA6	—
13	EJE/STEM	1.4401	1.4301	—
12	PIN	1.4401	1.4301	—
11	PERNO/BOLT (2)	1.4401	1.4301	—
10	ARANDELA/WASHER	1.4401	—	—
9	TUERCA/NUT	1.4401	—	—
8	TORNILLO/SCREW	1.4401	—	—
7	PALANCA/LEVER	1.4401	1.4301	—
6	BRAZO/ARM (x2)	1.4401	1.4301	—
5	TUERCA/NUT	1.4401	1.4301	—
4	ENTRONQUE/NIPPLE	1.4408	1.4301	SHOT BLASTING + PICKLING
3	ASIENTO/SEAT	Silicone	Silicone	—
2	DISCO/DISC	1.4401	1.4301	—
1	CUERPO/BODY	1.4408	1.4301	SHOT BLASTING + PICKLING (2856/2856N)
Pos. N	Denominación/Name	2856/2856N	3886	Acabado/Finishing
		Material		

**Art. 2856 (3"-4"):**

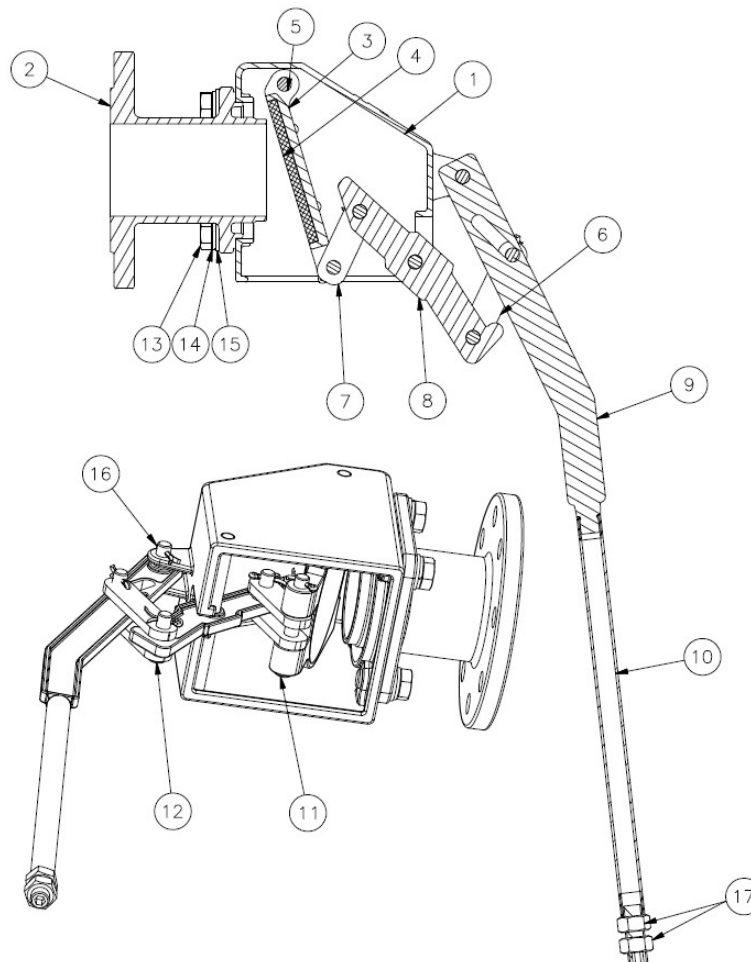

**-Fig. 2-**

17	TUERCA/NUT (x2)	1.4401	—
16	PASADOR/SPLIT PIN (x5)	1.4401	—
15	ARANDELA/WASHER (x4)	1.4401	—
14	ARANDELA/WASHER (x4)	1.4401	—
13	TORNILLO/SCREW	1.4401	—
12	PIN (x4)	1.4401	—
11	PIN	1.4401	—
10	TUBO/PIPE	1.4401	—
9	PALANCA/LEVER	1.4401	—
8	BRAZO/ARM	1.4408	SHOT BLASTING + PICKLING
7	UNIÓN/CONNECTOR (x2)	1.4408	—
6	UNIÓN/CONNECTOR (x2)	1.4408	—
5	PERNO/BOLT (x2)	1.4401	—
4	ASIENTO/SEAT	SILICONE	—
3	DISCO/DISC	1.4408	SHOT BLASTING + PICKLING
2	BRIDA/FLANGE	1.4408	SHOT BLASTING + PICKLING
1	CUERPO/BODY	1.4408	SHOT BLASTING + PICKLING
Pos. N	Denominación/Name	Material	Acabado/Finishing

### 3) Storage

If the valve is not installed immediately, it is recommended that the protective packaging not be removed to prevent any blows or the accumulation of dirt. This packaging should not be removed unless the valve is going to be installed. Where possible, the valves must be stored in a dry clean place.

## 4) Installation Instructions

### 4.1) Preparation

Remove any remains of packing material from the valve.

Significant problems may arise with any valve installed onto dirty piping.

*Ensure that the pipe is free from dirt, welding particles, etc. prior to installation as the valve may suffer irreparable damage during the start-up of the equipment → prepare a clean working area.*

Make sure there is enough space for future maintenance operations.

Check the correct functioning of the valve by turning the lever. The valve must open/close the disc. If this is not the case, check that there are no foreign bodies in the interior of the valve and repeat the operation. If the disc does not turn and close, the valve must not be installed. In case of vibrations in the pipe it is strongly recommended to mount anti-vibration elements to absorb them. Otherwise, the life of the product could be drastically reduced.

## 4.2) Assembly

Genebre, S.A. recommends install Floating Valves as shown in -Fig. 3-:

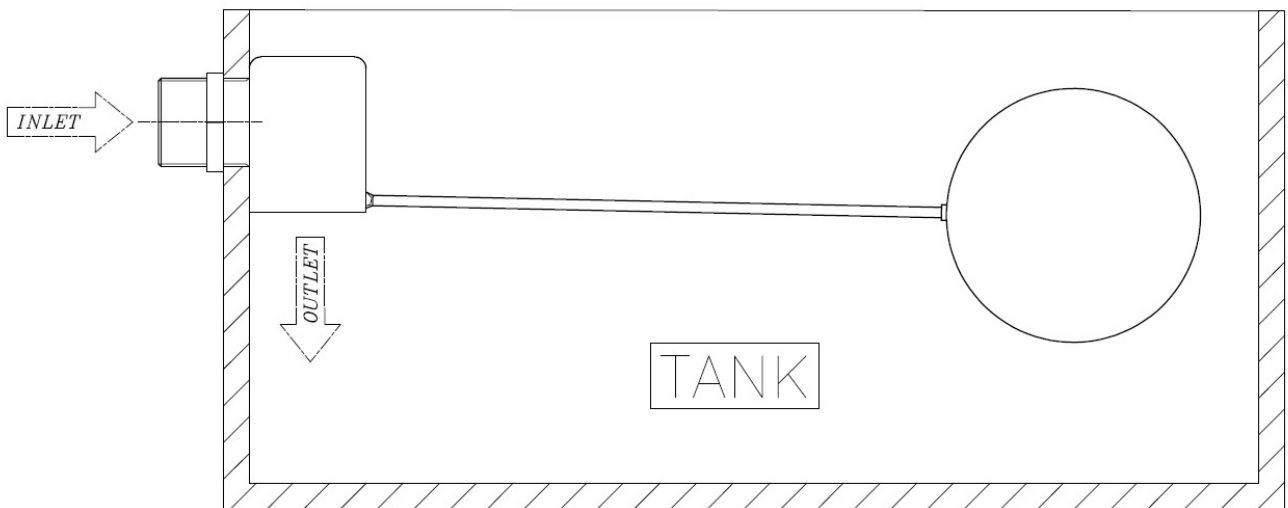

-Fig. 3-



For Floating Valves with NPT thread (art. 2856N), it is advised to weld a female threaded socket (art. 0270N) in the inner part of the tank.

### **IMPORTANT:**

- Do not disassemble the valves when installing them.
- Ensure that the pipe and valve thread are clean and that they are compatible (thread type).
- Apply a suitable sealer on the pipe threads and fasten the valve to the pipe taking care not to over tighten the tapered threads.
- Do not perform any welding when the valve has been assembled as it could be damaged by overheating and the seat area may deform.

- We recommend fastening the valve to the pipe using an open-ended or an adjustable spanner and by only applying force on the nut of the valve end.
- Avoid as much as possible the installation of elbows, reducers, valves or pumps near the valve to prevent turbulences. The minimum distance recommended between these elements is 10 times the pipe diameter (upstream) according to CR 13932:2000.

## 5) Operating Instructions

### 5.1) Use

Floating valves work automatically and does not require auxiliary power. Soft-seated valves provide a tight seal when used in accordance with the pressure / temperature values for which they have been designed.

The material from which the valve body and the rest of components are made must be compatible with the fluid circulating through the valve; otherwise, the valve may become seriously damaged.



**A floating valve does not represent any overpressure protection valve. If an overpressure limitation is necessary, ensure it by installing an appropriate valve**

### 5.2) Operation

This type of valve, by definition, does not require operating. The valve opens and closes automatically depending on the fluid level in the tank. For further information on the flow rate of the valve according to the inlet pressure, consult the technical data sheet of the product.

## 6) Maintenance Instructions

The floating valves are designed in such a way that they do not require any regular lubrication or maintenance during their useful lives.

However, the following checks will aid in prolonging the useful life of the valve and reduce problems during installation:

- maintain the valve in a totally closed position
- verify that all the threaded joints and fasteners are neither loose nor rusty. Fasten as required
- inspect the valve and the surrounding areas verifying that there are no leaks

## 7) Repair Instructions

If the fluid continues to circulate through the piping when the valve is completely closed, the leak is due to either the seal surface being damaged or an excessive wear of the metal parts as a result of metal fatigue after many continuous operation cycles. In both cases, the valve will require disassembling in order to carry out any repair. GENE BRE, S.A. can provide spare *Silicone Seats* as replacements (Genebre Ref: JS2856) only for art. 2856/2856N. However, in some cases the repair of a valve may not be advisable due to economic reasons (for example, areas of limited access) and a complete replacement should be carried out instead.

### 7.1) Disassembly

In order to carry out repair work, it is necessary to remove the valve from the installation.

*Ensure that the piping is cold, drained and depressurised.*

*Prepare a clean work area and the appropriate tools for the mechanical tasks.*

#### **(art. 2856/2856N ≤ 2 1/2") - Fig.1**

- a.- Place the valve on a suitable vice, holding it by its *body* (part. 1)
- b.- Slowly unscrew the two *bolts* (part. 1) until removed holding the *lever* (part. 7)
- c.- Remove from the body all the internal parts taking out the *lever* (part. 7)
- d.- Remove the *screw*, the *washer* and the *nut* (part. 8-9-10) in order to extract the *Silicone Seat* (part. 3) from the *disc* (part. 2)

#### **(art. 2856 3" - 4") - Fig. 2**

- a.- Place the valve on a suitable vice, holding it by its *body* (part. 1)
- b.- Slowly unscrew the two *bolts* (part. 5) until removed holding the *lever* (part. 9/10)
- c.- Take the *disc* (part. 3) out of the *body* (part. 1).
- d.- Using a flat screwdriver (or similar, extract the Silicone seat (part. 4) from its housing, helping yourself by simultaneously pushing the seat pins.

### 7.2) Reassembly



Before reassembling the valve, ensure that the repair kit and/or the parts to be used are appropriate and are the originals from the factory (Silicone Seat ref. JS2856).  
When the valve is reset, cleaning is essential for a long useful life of the valve.

## **(art. 2856/2856N ≤ 2 1/2") - Fig.1**

- a.- Clean the sealing area inside the *body*
- b.- Install a brand-new *Silicone Seat* (part. 3) together with the *disc* (part. 2) in their working position, using the *screw*, the *washer* and the *nut* (part. 8-9-10)
- c.- Introduce the *disc* (part. 2) in the *body* (part. 1) and screw them together with the two *bolts* (part. 11)
- d.- Check the function carefully and install the valve on the pipe again. See 4) *Installation Instructions*

## **(art. 2856 3" - 4") - Fig. 2**

- a.- Clean the sealing area inside the *body*
- b.- Place a new Silicone seat (part. 4) in its working position and fix it by pressing the pins.
- c.- Introduce the *disc* (part. 3) in the *body* (part. 1) and screw them together with the two *bolts* (part. 5/11)
- d.- Check the function carefully and install the valve on the pipe again. See 4) *Installation Instructions*

## **8) Health and Safety**

**8.1)** The fluids that pass through a valve can be corrosive, toxic, flammable or of a contaminating nature. They can also be found at very high or low temperature. When handling the valves, take the necessary safety measures, and it is advisable to use personal protective equipment:

- 1) Wear eye protection
- 2) Wear appropriate gloves and work clothes
- 3) Wear safety shoes
- 4) Wear a helmet
- 5) Check the availability of running water
- 6) In the case of flammable fluids, ensure that the appropriate extinguisher is available

**8.2) Before removing a valve from any piping, always ensure that the line is completely cold, drained and depressurised.**

**8.3)** Any valve that has been used in toxic services must have a certificate of cleaning before it is handled.

**8.4)** Any type of repair or maintenance should be performed in ventilated places.