

NO	PART NAME	MATERIAL
1	HANDLE HEAD	CF8
2	ANCHOR	CF8
3	ANCHOR SCREW	SS304
4	SPRING ROD	SS304
5	SPRING	SPRING STEEL
6	HANDLE EXTENSION	SS304
7	SLEEVE	PVC
8	WASHER	SS304
9	HEX NUT	SS304

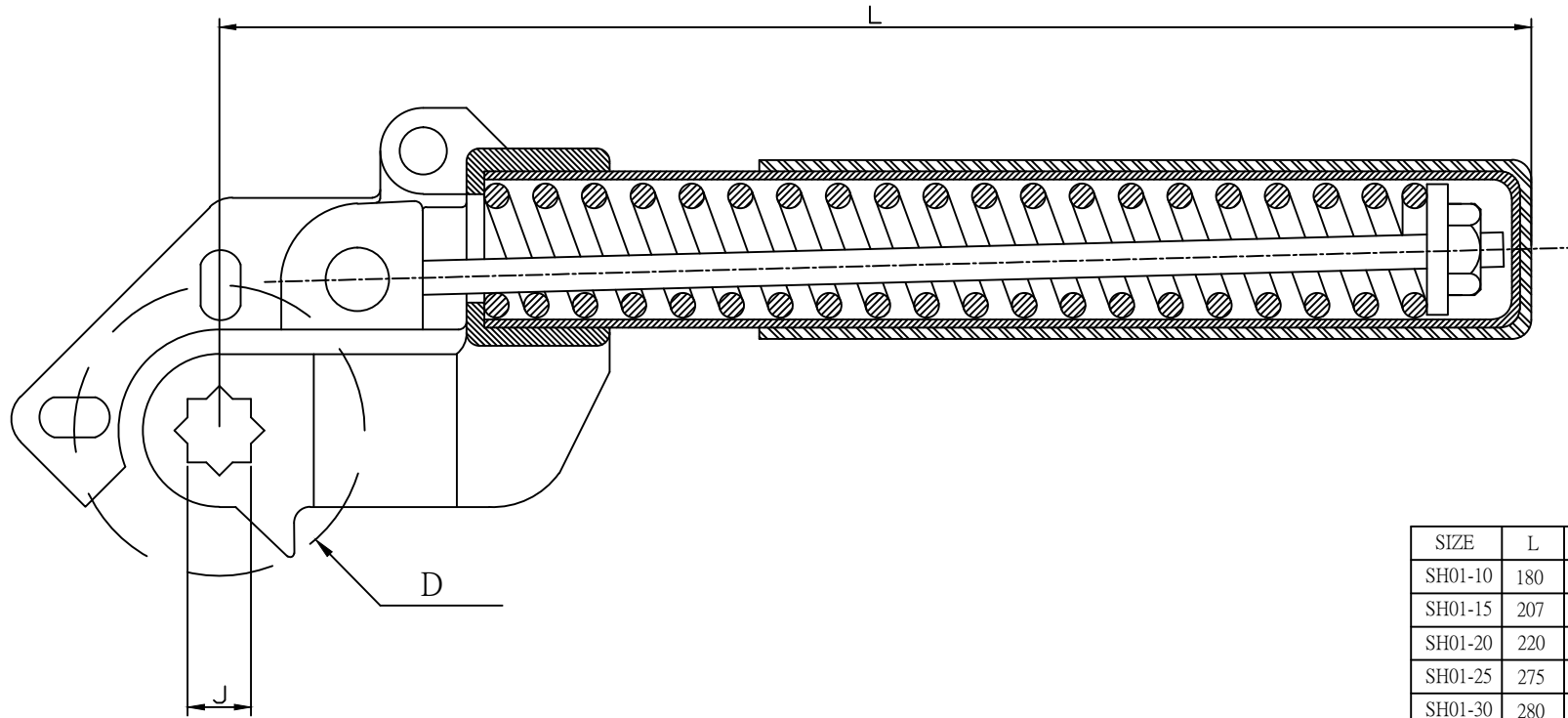

DIMENSIONS

SIZE	L	J	TORQUE	D(ISO5211)
SH01-10	180	9	15Nm	F03/F04
SH01-15	207	9	20Nm	F03/F04
SH01-20	220	11	20Nm	F04/F05
SH01-25	275	11	30Nm	F04/F05
SH01-30	280	14	30Nm	F05/F07
SH01-35	450	14	55Nm	F05/F07
SH01-40	500	17/22	100Nm	F10/F12

繪圖	比例	材質	料號	盈昶國際有限公司 YZNG TRONG INTERNATIONAL CO.,LTD	說明	修正者	核准
DRAWN	SCALE	MATERIAL	PART				
核准	單位	日期	圖號	SPRING RETURN HANDLE	DESCRIPTION	DEVISER	APPROVED
APPROVED	UNIT	DATE	DRAWING				